

# 544 P

Wheel Loader



JOHN DEERE



# ELEVATE YOUR EXPECTATIONS



AVS ON THE G5 DISPLAY



SMARTDETECT ON THE G5 DISPLAY

## VISION AND DETECTION SYSTEM OFFERINGS

Active jobsites present many operational challenges, including multiple machines, crew members, and bystanders. The John Deere Advanced Vision System (AVS) and SmartDetect™ can help enhance operator awareness to confidently navigate busy work areas:

- Optional **AVS** includes two digital cameras mounted on the rearview-mirror platforms that integrate with the rearview (backup) camera for a single display on a dedicated in-cab monitor.
- Paired with a high-resolution camera and a dedicated display, optional **Advanced Rear Object-Detection System (ARODS)** utilizes a radar system that provides audible alerts when objects are detected at the rear of the machine. ARODS helps operators visualize the loader's reversal path based on its articulation.
- Now available as an easily installed field kit, optional **SmartDetect** alerts operators of objects entering the machine's projected travel path, emitting sound and visual alerts inside the cab as well as an audible alarm to detected bystanders. SmartDetect requires AVS, ARODS, and a G5 display as well as software activation.

# ABOVE AND BEYOND

## MEET THE P-TIER WHEEL LOADERS



**SMARTWEIGH™**  
**PAYLOAD-WEIGHING**  
**SOLUTION IS DEERE**  
**DESIGNED & SUPPORTED**

When your material-handling application needs a heavy-duty lift, add a P-Tier Wheel Loader to your lineup. Combining convenient front-end features with near-parallel lift, spacious operator stations including customizable ergonomic electrohydraulic (EH) controls, streamlined electrical and hydraulic routing, and innovative options, these versatile and productive mid-size models are designed to help you take your operation to the next level.

### Take control

Operators can easily control up to six functions without letting go of the ergonomically designed joystick. Two industry-exclusive multifunction buttons can each be programmed to handle any of up to 10 functions selected through the monitor, including bucket vibrate and EH Precision mode.

### On your side

All daily service points including fuel refill are conveniently grouped at ground level on the left side of the machine for easy access. Routing of electrical wire harnesses and hydraulic hoses has been streamlined.

### Level up

AutoLevel enables near-perfect parallelism throughout the boom-raise-and-lower cycle, letting operators set their desired attachment angle to within  $\pm$  two degrees.

### At the forefront

Featuring bucket and linkage designs that improve load leveling, material retention, and visibility, P-Tier Loaders yield more productivity and performance than previous models. Enhanced-performance buckets with integrated spill guards, curved side cutters, and impressive rollback deliver elevated bucket-fill performance and material retention compared to earlier offerings.

### Material matters

SmartWeigh option features dynamic weighing technology that allows operators to weigh without interrupting workflow and removes the need to lower and reraise the boom after tipoff. Shared through the onboard monitor, SmartWeigh is easy to calibrate and effortlessly integrates with the John Deere Operations Center™ so you can track and visualize payload data from almost anywhere. Available as a factory-installed or field-kit option, you can also try SmartWeigh at a low cost for 250 machine hours.



# OVERACHIEVERS

## ASPIRE TO GO HIGHER.

With handy front-end features and plenty of productivity-boosting enhancements over previous models, our 544 P-Tier Wheel Loader redefines expectations about the heights a utility loader can reach.



### Have a seat

Spacious and comfortable cab features extra legroom, an improved HVAC system, additional storage, and a more adjustable seat than earlier models.



### Near-parallel lift

Lift path on Z-Bar linkage is near parallel. Better load-leveling capability compared to K-Series models minimizes load rollback, reduces material spillage, and requires fewer manual adjustments. Cross-tube and boom geometry of the Z-Bar linkage has been streamlined to provide a better view to the front attachment.



### Pretty big plus

High-Lift Plus configuration provides an additional 24 inches of hinge-pin height over standard lift height and 12 inches over the High-Lift model. All three lift heights feature near-parallel lift.



### Clear advantage

Improved visibility to the work tool helps reduce spillage as well as cycle and tool-changeover times. It also helps minimize machine damage when working on crowded jobsites or up against walls.



### Connected machines

John Deere construction equipment comes with in-base connectivity — free from subscriptions or annual renewals. Analyze critical machine data, track utilization, review diagnostic alerts, and more from **the John Deere Operations Center**. The Operations Center also enables **John Deere Connected Support™**, which uses data from thousands of connected machines to proactively address issues before they arise. With your approval, your dealer can also remotely monitor machine health, diagnose problems, and even update machine software without a trip to the jobsite.\*

\*Availability varies by region and product. Options not available in every country.





**544 P**

**WHEEL LOADER**

**3" MORE LEGROOM**  
THAN K-SERIES CABS





While general information, pictures, and descriptions are provided, some illustrations and text may include product options and accessories NOT AVAILABLE in all regions, and in some countries products and accessories may require modifications or additions to ensure compliance with the local regulations of those countries.

<b>Engine</b>		<b>544 P-TIER Z-BAR / HIGH-LIFT / HIGH-LIFT PLUS</b>		
Manufacturer and Model	John Deere PowerTech™ PVS 6068	Gross Peak Torque (ISO 9249)	770 Nm (568 ft.-lb.) at 1,600 rpm	
Non-Road Emission Standard	EPA Final Tier 4/EU Stage V	Net Torque Rise	47%	
Cylinders	6	Fuel System (electronically controlled)	High-pressure common rail	
Valves Per Cylinder	4	Lubrication	Full-flow spin-on filter and integral cooler	
Displacement	6.8 L (414 cu. in.)	Aspiration	Turbocharged, charge air cooled	
Net Peak Power (ISO 9249)	123 kW (166 hp) at 1,700 rpm	Air Cleaner	Under-hood, dual-element dry type, restriction indicator in cab monitor for service	
Gross Peak Power (ISO 9249)	130 kW (174 hp) at 1,700 rpm			
Net Peak Torque (ISO 9249)	740 Nm (546 lb.-ft.) at 1,100 rpm			
<b>Cooling</b>				
Fan Drive	Hydraulically driven, proportionally controlled, fan aft of coolers			
<b>Electrical</b>				
Electrical System	24 volt with 100-amp alternator (optional 130-amp alternator)			
Batteries (2 – 12 volt)	950 CCA (each)			
<b>Transmission System</b>				
Type	Countershaft-type PowerShift™			
Torque Converter	Single stage, single phase			
Shift Control	Electronically modulated, adaptive, load and speed dependent			
Operator Interface	Steering-column or joystick-mounted F-N-R and gear-select lever; kick-down button on hydraulic lever			
Shift Modes	Manual/auto (1st-D or 2nd-D); Quick-Shift button with 2 selectable modes: kick-down or kick-up/down; and 4 clutch cutoff settings			
	<i>Standard 5-Speed With Lockup Torque Converter</i>		<i>Optional 5-Speed Without Lockup Torque Converter</i>	
Maximum Travel Speeds (with 20.5 R 25 tires)	<i>Forward</i>	<i>Reverse</i>	<i>Forward</i>	<i>Reverse</i>
Range 1	6.1 km/h (3.7 mph)	5.9 km/h (3.6 mph)	5.6 km/h (3.5 mph)	6.0 km/h (3.7 mph)
Range 2	12.0 km/h (7.4 mph)	12.7 km/h (7.8 mph)	11.2 km/h (7.0 mph)	11.9 km/h (7.3 mph)
Range 3	18.6 km/h (11.5 mph)	29.4 km/h (18.3 mph)	17.4 km/h (10.8 mph)	27.6 km/h (17.1 mph)
Range 4	27.9 km/h (17.3 mph)	N/A	26.2 km/h (16.2 mph)	N/A
Range 5	40.0 km/h (24.8 mph)	N/A	40.0 km/h (24.8 mph)	N/A
<b>Axles/Brakes</b>				
Final Drives	Heavy-duty inboard-mounted planetary			
Differentials	Hydraulic locking front with conventional rear – standard; dual locking front and rear – optional			
Rear Axle Oscillation, Stop to Stop (with 20.5 R 25 tires)	24 deg. (12 deg. each direction)			
Brakes (conform to ISO 3450)				
Service	Hydraulically actuated, spring-retracted, self-adjusting inboard sun-shaft mounted, oil cooled, single disc			
Parking	Automatic spring applied, hydraulically released, driveline mounted, sealed wet multi disc			
<b>Tires/Wheels (see page 9 for complete tire adjustments)</b>				
	<i>Tread Width</i>	<i>Width Over Tires</i>		
Michelin 20.5 R 25, 1 Star L-3 XHA2	1950 mm (76.8 in.)	2546 mm (100.2 in.)		
<b>Serviceability</b>				
<b>Refill Capacities</b>		<b>Refill Capacities (continued)</b>		
Fuel Tank (with lockable cap)	298 L (79 gal.)	Axle Oil (each)		
Cooling System	29.9 L (31.6 qt.)	Front	16.6 L (17.5 qt.)	
Diesel Exhaust Fluid (DEF)	15.6 L (16.5 qt.)	Rear	18 L (19 qt.)	
Engine Oil With Vertical Spin-On Filter	19.5 L (20.6 qt.)	Hydraulic Reservoir and Filter	82.1 L (21.7 gal.)	
Transmission Reservoir With Vertical Filter	21 L (22.2 qt.)	Park Brake Oil (wet disc)	0.3 L (10 oz.)	
<b>Hydraulic System/Steering</b>				
Pump (loader and steering)	Variable-displacement, axial-piston pump; closed-center, pressure-compensating system			
Maximum Rated Flow at 6895 kPa (1,000 psi) and 2,200 rpm	220 L/m (58 gpm)			
System Relief Pressure (loader and steering)	25 166 kPa (3,650 psi)			
Loader Controls	2-function valve, joystick control or fingertip controls, hydraulic-function enable/disable, optional 3rd- and 4th-function valve with auxiliary lever			
Steering (conforms to ISO 5010)	Steering-column-mounted, twist-grip shift lever; Quick-Shift button on hydraulic lever			
Type	Power, fully hydraulic			
Articulation Angle	80-deg. arc (40 deg. each direction)			
Turning Radius (measured to centerline of outside tire)	5.0 m (16 ft. 5 in.)			

# 544 P-TIER WHEEL LOADER SPECIFICATIONS

# 544

# P

While general information, pictures, and descriptions are provided, some illustrations and text may include product options and accessories NOT AVAILABLE in all regions, and in some countries products and accessories may require modifications or additions to ensure compliance with the local regulations of those countries.

### Hydraulic System/Steering (continued) 544 P-TIER Z-BAR / HIGH-LIFT / HIGH-LIFT PLUS

Hydraulic Cycle Times	Z-Bar / High-Lift / High-Lift Plus
Raise	5.5 sec.
Dump	2.2 sec.
Lower (power down)	3.5 sec.
Total	11.2 sec.

### Bucket Capacity Range

Bucket Type	
Pin-On	2.1–2.5 m <sup>3</sup> (2.75–3.25 cu. yd.)
Coupler	1.9–4.0 m <sup>3</sup> (2.5–5.25 cu. yd.)

### Dimensions and Specifications With Pin-On Bucket With Bolt-On Edge

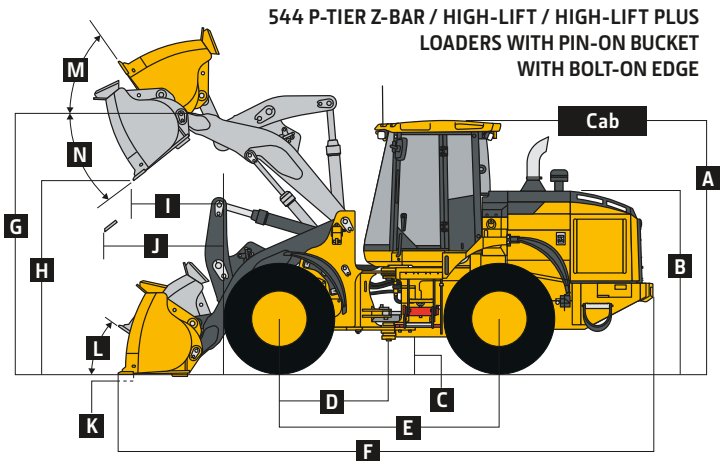

	Z-Bar	Z-Bar	High-Lift	High-Lift	High-Lift Plus	High-Lift Plus
<b>Dimensions With Bucket With Bolt-On Edge (illustration above right)</b>	2.3-m <sup>3</sup> (3.0 cu. yd.) enhanced performance	2.5-m <sup>3</sup> (3.25 cu. yd.) enhanced performance	2.1-m <sup>3</sup> (2.75 cu. yd.) enhanced performance	2.3-m <sup>3</sup> (3.0 cu. yd.) enhanced performance	2.1-m <sup>3</sup> (2.75 cu. yd.) enhanced performance	2.3-m <sup>3</sup> (3.0 cu. yd.) enhanced performance
<b>A</b> Height to Top of Cab	3.33 m (10 ft. 11 in.)	3.33 m (10 ft. 11 in.)	3.33 m (10 ft. 11 in.)	3.33 m (10 ft. 11 in.)	3.33 m (10 ft. 11 in.)	3.33 m (10 ft. 11 in.)
<b>B</b> Hood Height	2.375 m (7 ft. 9 in.)	2.375 m (7 ft. 9 in.)	2.375 m (7 ft. 9 in.)	2.375 m (7 ft. 9 in.)	2.375 m (7 ft. 9 in.)	2.375 m (7 ft. 9 in.)
<b>C</b> Ground Clearance	0.40 m (15.7 in.)	0.40 m (15.7 in.)	0.40 m (15.7 in.)	0.40 m (15.7 in.)	0.40 m (15.7 in.)	0.40 m (15.7 in.)
<b>D</b> Length From Centerline to Front Axle	1.45 m (4 ft. 9 in.)	1.45 m (4 ft. 9 in.)	1.45 m (4 ft. 9 in.)	1.45 m (4 ft. 9 in.)	1.45 m (4 ft. 9 in.)	1.45 m (4 ft. 9 in.)
<b>E</b> Wheelbase	2.93 m (9 ft. 7 in.)	2.93 m (9 ft. 7 in.)	2.93 m (9 ft. 7 in.)	2.93 m (9 ft. 7 in.)	2.93 m (9 ft. 7 in.)	2.93 m (9 ft. 7 in.)
<b>F</b> Overall Length, Bucket on Ground	7.49 m (24 ft. 7 in.)	7.49 m (24 ft. 7 in.)	7.80 m (25 ft. 7 in.)	7.88 m (25 ft. 10 in.)	8.17 m (26 ft. 10 in.)	8.25 m (27 ft. 1 in.)
<b>G</b> Height to Hinge Pin, Fully Raised	3.89 m (12 ft. 9 in.)	3.89 m (12 ft. 9 in.)	4.17 m (13 ft. 8 in.)	4.17 m (13 ft. 8 in.)	4.49 m (14 ft. 9 in.)	4.49 m (14 ft. 9 in.)
<b>H</b> Dump Clearance, 45 deg., Full Height	2.80 m (9 ft. 2 in.)	2.80 m (9 ft. 2 in.)	3.14 m (10 ft. 4 in.)	3.09 m (10 ft. 2 in.)	3.47 m (11 ft. 4 in.)	3.41 m (11 ft. 2 in.)
<b>I</b> Reach, 45-deg. Dump, Full Height	1.01 m (3 ft. 4 in.)	1.01 m (3 ft. 4 in.)	1.09 m (3 ft. 7 in.)	1.14 m (3 ft. 9 in.)	1.13 m (3 ft. 8 in.)	1.19 m (3 ft. 11 in.)
<b>J</b> Reach, 45-deg. Dump, 2.13-m (7 ft. 0 in.) Clearance	1.51 m (4 ft. 11 in.)	1.51 m (4 ft. 11 in.)	1.81 m (5 ft. 11 in.)	1.84 m (6 ft. 0 in.)	2.10 m (6 ft. 11 in.)	2.14 m (7 ft. 0 in.)
<b>K</b> Maximum Digging Depth	0.1 m (4 in.)	0.1 m (4 in.)	0.19 m (8 in.)	0.2 m (8 in.)	0.2 m (8 in.)	0.2 m (8 in.)
<b>L</b> Maximum Rollback at Ground Level	44 deg.	44 deg.	48 deg.	48 deg.	49 deg.	49 deg.
<b>M</b> Maximum Rollback, Boom Fully Raised	60 deg.	60 deg.	60 deg.	60 deg.	61 deg.	61 deg.
<b>N</b> Maximum Bucket Dump Angle, Fully Raised	48 deg.	48 deg.	46 deg.	46 deg.	45 deg.	45 deg.
Loader Clearance Circle, Bucket Carry Position	11.46 m (37 ft. 7 in.)	11.58 m (38 ft. 0 in.)	11.68 m (38 ft. 4 in.)	11.70 m (38 ft. 5 in.)	12.16 m (39 ft. 11 in.)	12.20 m (40 ft. 0 in.)
<b>Specifications With Bucket With Bolt-On Edge</b>						
Capacity, Heaped	2.3 m <sup>3</sup> (3.0 cu. yd.)	2.5 m <sup>3</sup> (3.25 cu. yd.)	2.1 m <sup>3</sup> (2.75 cu. yd.)	2.3 m <sup>3</sup> (3.0 cu. yd.)	2.1 m <sup>3</sup> (2.75 cu. yd.)	2.3 m <sup>3</sup> (3.0 cu. yd.)
Capacity, Struck	1.9 m <sup>3</sup> (2.5 cu. yd.)	2.1 m <sup>3</sup> (2.7 cu. yd.)	1.7 m <sup>3</sup> (2.3 cu. yd.)	1.9 m <sup>3</sup> (2.5 cu. yd.)	1.7 m <sup>3</sup> (2.3 cu. yd.)	1.9 m <sup>3</sup> (2.5 cu. yd.)
Bucket Weight With Bolt-On Cutting Edge	1095 kg (2,415 lb.)	1131 kg (2,493 lb.)	1056 kg (2,327 lb.)	1095 kg (2,415 lb.)	1056 kg (2,327 lb.)	1095 kg (2,415 lb.)
Bucket Width	2.54 m (8 ft. 4 in.)	2.68 m (8 ft. 10 in.)	2.55 m (8 ft. 4 in.)	2.54 m (8 ft. 4 in.)	2.55 m (8 ft. 4 in.)	2.54 m (8 ft. 4 in.)
Breakout Force	13 166 kg (29,026 lb.)	13 145 kg (28,979 lb.)	13 983 kg (30,827 lb.)	13 005 kg (28,672 lb.)	14 138 kg (31,168 lb.)	13 149 kg (28,988 lb.)
Tipping Load, Straight, No Tire Deflection	11 139 kg (24,557 lb.)	11 097 kg (24,464 lb.)	9699 kg (21,384 lb.)	9591 kg (21,145 lb.)	8630 kg (19,026 lb.)	8537 kg (18,820 lb.)
Tipping Load, Straight, With Tire Deflection	10 533 kg (23,221 lb.)	10 491 kg (23,129 lb.)	9231 kg (20,351 lb.)	9120 kg (20,106 lb.)	8244 kg (18,175 lb.)	8145 kg (17,957 lb.)
Tipping Load, 40-deg. Full Turn, No Tire Deflection	9653 kg (21,281 lb.)	9612 kg (21,190 lb.)	8374 kg (18,460 lb.)	8274 kg (18,241 lb.)	7410 kg (16,336 lb.)	7323 kg (16,145 lb.)
Tipping Load, 40-deg. Full Turn, With Tire Deflection	8865 kg (19,544 lb.)	8823 kg (19,451 lb.)	7755 kg (17,097 lb.)	7650 kg (16,865 lb.)	6891 kg (15,192 lb.)	6807 kg (15,007 lb.)
Rated Operating Load, 50% Full-Turn Tipping Load, No Tire Deflection (conforms to ISO 14397-1)*	4827 kg (10,641 lb.)	4806 kg (10,595 lb.)	4187 kg (9,230 lb.)	4137 kg (9,120 lb.)	3705 kg (8,168 lb.)	3662 kg (8,073 lb.)
Rated Operating Load, 50% Full-Turn Tipping Load, With Tire Deflection (conforms to ISO 14397-1)*	4433 kg (9,772 lb.)	4412 kg (9,726 lb.)	3878 kg (8,548 lb.)	3825 kg (8,433 lb.)	3446 kg (7,596 lb.)	3404 kg (7,503 lb.)
Operating Weight	13 844 kg (30,520 lb.)	13 879 kg (30,598 lb.)	13 992 kg (30,847 lb.)	14 032 kg (30,935 lb.)	14 178 kg (31,257 lb.)	14 218 kg (31,345 lb.)

Loader operating information is based on machine with identified linkage and standard equipment, PowerTech PVS 6068 (EPA Final Tier 4/EU Stage V) engine, ROPS cab, rear cast bumper/counterweight, transmission side-frame guards, bottom guards, standard tires, full fuel tank, and 79-kg (175 lb.) operator. This information is affected by changes in tires, ballast, and different attachments.

\*Rated operating capacity based on Deere attachments only.

# 544 P-TIER

While general information, pictures, and descriptions are provided, some illustrations and text may include product options and accessories NOT AVAILABLE in all regions, and in some countries products and accessories may require modifications or additions to ensure compliance with the local regulations of those countries.

**Dimensions and Specifications With Hi-Vis Coupler and Hook-On Bucket With Bolt-On Edge**      **544 P-TIER Z-BAR / HIGH-LIFT / HIGH-LIFT PLUS**

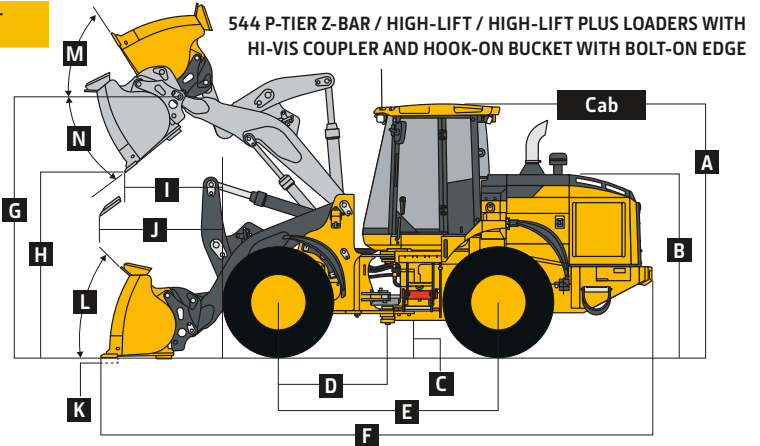

	Z-Bar 2.3-m <sup>3</sup> (3.0 cu. yd.)	Z-Bar 2.5-m <sup>3</sup> (3.25 cu. yd.)	Z-Bar 3.4-m <sup>3</sup> (4.5 cu. yd.)	High-Lift 2.1-m <sup>3</sup> (2.75 cu. yd.)	High-Lift 2.3-m <sup>3</sup> (3.0 cu. yd.)	High-Lift 3.1-m <sup>3</sup> (4.0 cu. yd.)	High-Lift Plus 1.9-m <sup>3</sup> (2.5 cu. yd.)	High-Lift Plus 3.1-m <sup>3</sup> (4.0 cu. yd.)
<b>Dimensions With Bucket With Bolt-On Edge (illustration above right)</b>								
<b>A</b> Height to Top of Cab	3.33 m (10 ft. 11 in.)	3.33 m (10 ft. 11 in.)	3.33 m (10 ft. 11 in.)	3.33 m (10 ft. 11 in.)	3.33 m (10 ft. 11 in.)	3.33 m (10 ft. 11 in.)	3.33 m (10 ft. 11 in.)	3.33 m (10 ft. 11 in.)
<b>B</b> Hood Height	2.375 m (7 ft. 9 in.)	2.375 m (7 ft. 9 in.)	2.375 m (7 ft. 9 in.)	2.375 m (7 ft. 9 in.)	2.375 m (7 ft. 9 in.)	2.375 m (7 ft. 9 in.)	2.375 m (7 ft. 9 in.)	2.375 m (7 ft. 9 in.)
<b>C</b> Ground Clearance	0.40 m (15.7 in.)	0.40 m (15.7 in.)	0.40 m (15.7 in.)	0.40 m (15.7 in.)	0.40 m (15.7 in.)	0.40 m (15.7 in.)	0.40 m (15.7 in.)	0.40 m (15.7 in.)
<b>D</b> Length From Centerline to Front Axle	1.45 m (4 ft. 9 in.)	1.45 m (4 ft. 9 in.)	1.45 m (4 ft. 9 in.)	1.45 m (4 ft. 9 in.)	1.45 m (4 ft. 9 in.)	1.45 m (4 ft. 9 in.)	1.45 m (4 ft. 9 in.)	1.45 m (4 ft. 9 in.)
<b>E</b> Wheelbase	2.93 m (9 ft. 7 in.)	2.93 m (9 ft. 7 in.)	2.93 m (9 ft. 7 in.)	2.93 m (9 ft. 7 in.)	2.93 m (9 ft. 7 in.)	2.93 m (9 ft. 7 in.)	2.93 m (9 ft. 7 in.)	2.93 m (9 ft. 7 in.)
<b>F</b> Overall Length, Bucket on Ground	7.56 m (24 ft. 10 in.)	7.64 m (25 ft. 1 in.)	7.83 m (25 ft. 8 in.)	7.95 m (26 ft. 1 in.)	7.95 m (26 ft. 1 in.)	8.08 m (26 ft. 6 in.)	8.23 m (27 ft. 0 in.)	8.45 m (27 ft. 9 in.)
<b>G</b> Height to Hinge Pin, Fully Raised	3.89 m (12 ft. 9 in.)	3.89 m (12 ft. 9 in.)	3.89 m (12 ft. 9 in.)	4.17 m (13 ft. 8 in.)	4.17 m (13 ft. 8 in.)	4.17 m (13 ft. 8 in.)	4.49 m (14 ft. 9 in.)	4.49 m (14 ft. 9 in.)
<b>H</b> Dump Clearance, 45 deg., Full Height	2.76 m (9 ft. 1 in.)	2.70 m (8 ft. 10 in.)	2.58 m (8 ft. 6 in.)	3.04 m (10 ft. 0 in.)	3.04 m (10 ft. 0 in.)	2.96 m (9 ft. 9 in.)	3.43 m (11 ft. 3 in.)	3.28 m (10 ft. 9 in.)
<b>I</b> Reach, 45-deg. Dump, Full Height	1.06 m (3 ft. 6 in.)	1.12 m (3 ft. 8 in.)	1.25 m (4 ft. 1 in.)	1.19 m (3 ft. 11 in.)	1.19 m (3 ft. 11 in.)	1.29 m (4 ft. 3 in.)	1.17 m (3 ft. 10 in.)	1.33 m (4 ft. 5 in.)
<b>J</b> Reach, 45-deg. Dump, 2.13-m (7 ft. 0 in.) Clearance	1.54 m (5 ft. 1 in.)	1.56 m (5 ft. 1 in.)	1.62 m (5 ft. 4 in.)	1.87 m (6 ft. 2 in.)	1.87 m (6 ft. 2 in.)	1.92 m (6 ft. 4 in.)	2.13 m (7 ft. 0 in.)	2.23 m (7 ft. 4 in.)
<b>K</b> Maximum Digging Depth	0.1 m (4 in.)	0.11 m (4 in.)	0.11 m (5 in.)	0.2 m (8 in.)	0.2 m (8 in.)	0.2 m (8 in.)	0.2 m (8 in.)	0.21 m (8 in.)
<b>L</b> Maximum Rollback at Ground Level	44 deg.	44 deg.	44 deg.	48 deg.	48 deg.	48 deg.	49 deg.	49 deg.
<b>M</b> Maximum Rollback, Boom Fully Raised	60 deg.	60 deg.	60 deg.	60 deg.	60 deg.	60 deg.	61 deg.	61 deg.
<b>N</b> Maximum Bucket Dump Angle, Fully Raised	48 deg.	48 deg.	48 deg.	46 deg.	46 deg.	46 deg.	45 deg.	45 deg.
Loader Clearance Circle, Bucket Carry Position	11.60 m (38 ft. 1 in.)	11.60 m (38 ft. 0 in.)	11.88 m (39 ft. 0 in.)	11.78 m (38 ft. 8 in.)	11.86 m (38 ft. 11 in.)	12.22 m (40 ft. 1 in.)	12.62 m (39 ft. 9 in.)	12.62 m (41 ft. 5 in.)
<b>Specifications With Bucket With Bolt-On Edge</b>								
Capacity, Heaped	2.3 m <sup>3</sup> (3.0 cu. yd.)	2.5 m <sup>3</sup> (3.25 cu. yd.)	3.4 m <sup>3</sup> (4.5 cu. yd.)	2.1 m <sup>3</sup> (2.75 cu. yd.)	2.3 m <sup>3</sup> (3.0 cu. yd.)	3.1 m <sup>3</sup> (4.0 cu. yd.)	1.9 m <sup>3</sup> (2.5 cu. yd.)	3.1 m <sup>3</sup> (4.0 cu. yd.)
Capacity, Struck	1.9 m <sup>3</sup> (2.4 cu. yd.)	2.1 m <sup>3</sup> (2.7 cu. yd.)	2.9 m <sup>3</sup> (3.8 cu. yd.)	1.9 m <sup>3</sup> (2.4 cu. yd.)	1.9 m <sup>3</sup> (2.4 cu. yd.)	2.5 m <sup>3</sup> (3.3 cu. yd.)	1.6 m <sup>3</sup> (2.1 cu. yd.)	2.5 m <sup>3</sup> (3.3 cu. yd.)
Bucket Weight With Bolt-On Cutting Edge	1489 kg (3,283 lb.)	1537 kg (3,388 lb.)	1747 kg (3,850 lb.)	1454 kg (3,205 lb.)	1489 kg (3,283 lb.)	1683 kg (3,711 lb.)	1385 kg (3,052 lb.)	1683 kg (3,711 lb.)
Bucket Width	2.68 m (8 ft. 10 in.)	2.68 m (8 ft. 10 in.)	2.89 m (9 ft. 6 in.)	2.55 m (8 ft. 4 in.)	2.68 m (8 ft. 10 in.)	2.89 m (9 ft. 6 in.)	2.55 m (8 ft. 4 in.)	2.89 m (9 ft. 6 in.)
Breakout Force	12 307 kg (27,131 lb.)	11 539 kg (25,439 lb.)	10 013 kg (22,074 lb.)	12 179 kg (26,849 lb.)	12 155 kg (26,797 lb.)	10 907 kg (24,045 lb.)	13 305 kg (29,333 lb.)	11 028 kg (24,313 lb.)
Tipping Load, Straight, No Tire Deflection	10 362 kg (22,844 lb.)	10 250 kg (22,597 lb.)	9912 kg (21,853 lb.)	8963 kg (19,759 lb.)	8910 kg (19,642 lb.)	8663 kg (19,099 lb.)	8085 kg (17,825 lb.)	7679 kg (16,614 lb.)
Tipping Load, Straight, With Tire Deflection	9789 kg (21,581 lb.)	9675 kg (21,330 lb.)	9321 kg (20,549 lb.)	8508 kg (18,757 lb.)	8460 kg (18,651 lb.)	8199 kg (18,076 lb.)	7713 kg (17,004 lb.)	7290 kg (16,174 lb.)
Tipping Load, 40-deg. Full Turn, No Tire Deflection	8931 kg (19,690 lb.)	8827 kg (19,459 lb.)	8499 kg (18,736 lb.)	7686 kg (16,945 lb.)	7635 kg (16,833 lb.)	7390 kg (16,293 lb.)	6899 kg (15,209 lb.)	6501 kg (14,040 lb.)
Tipping Load, 40-deg. Full Turn, With Tire Deflection	8181 kg (18,036 lb.)	8073 kg (17,798 lb.)	7731 kg (17,044 lb.)	7083 kg (15,615 lb.)	7035 kg (15,510 lb.)	6771 kg (14,927 lb.)	6393 kg (14,094 lb.)	5988 kg (12,884 lb.)
Rated Operating Load, 50% Full-Turn Tipping Load, No Tire Deflection (conforms to ISO 14397-1)*	4466 kg (9,845 lb.)	4413 kg (9,730 lb.)	4249 kg (9,368 lb.)	3843 kg (8,473 lb.)	3818 kg (8,417 lb.)	3695 kg (8,146 lb.)	3449 kg (7,604 lb.)	3251 kg (7,020 lb.)
Rated Operating Load, 50% Full-Turn Tipping Load, With Tire Deflection (conforms to ISO 14397-1)*	4091 kg (9,018 lb.)	4037 kg (8,899 lb.)	3866 kg (8,522 lb.)	3542 kg (7,808 lb.)	3518 kg (7,755 lb.)	3386 kg (7,464 lb.)	3197 kg (7,047 lb.)	2994 kg (6,442 lb.)
Operating Weight	14 258 kg (31,433 lb.)	14 305 kg (31,538 lb.)	14 515 kg (32,000 lb.)	14 411 kg (31,771 lb.)	14 446 kg (31,849 lb.)	14 641 kg (32,277 lb.)	14 528 kg (32,029 lb.)	14 827 kg (32,827 lb.)

Loader operating information is based on machine with identified linkage and standard equipment, PowerTech PVS 6068 (EPA Final Tier 4/EU Stage VI) engine, ROPS cab, rear cast bumper/counterweight, transmission side-frame guards, bottom guards, standard tires, full fuel tank, and 79-kg (175 lb.) operator. This information is affected by changes in tires, ballast, and different attachments. / \*Rated operating capacity based on Deere attachments only.



While general information, pictures, and descriptions are provided, some illustrations and text may include product options and accessories NOT AVAILABLE in all regions, and in some countries products and accessories may require modifications or additions to ensure compliance with the local regulations of those countries.

# 544 P-TIER

## Dimensions and Specifications With Hi-Vis Coupler and Hook-On Construction Forks

## 544 P-TIER Z-BAR / HIGH-LIFT / HIGH-LIFT PLUS

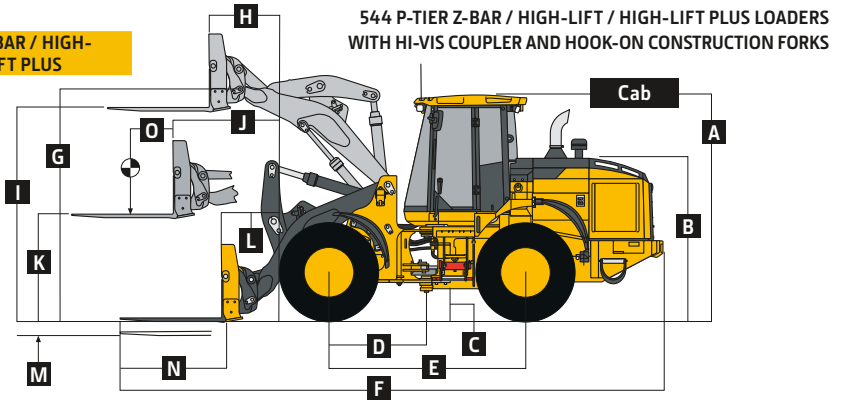

544 P-TIER Z-BAR / HIGH-LIFT / HIGH-LIFT PLUS LOADERS WITH HI-VIS COUPLER AND HOOK-ON CONSTRUCTION FORKS

	Z-Bar 1.52-m (60 in.) tine length	Z-Bar 1.83-m (72 in.) tine length	High-Lift 1.52-m (60 in.) tine length	High-Lift 1.83-m (72 in.) tine length	High-Lift Plus 1.52-m (60 in.) tine length	High-Lift Plus 1.83-m (72 in.) tine length
<b>A</b> Height to Top of Cab	3.33 m (10 ft. 11 in.)	3.33 m (10 ft. 11 in.)	3.33 m (10 ft. 11 in.)	3.33 m (10 ft. 11 in.)	3.33 m (10 ft. 11 in.)	3.33 m (10 ft. 11 in.)
<b>B</b> Hood Height	2.375 m (7 ft. 9 in.)	2.375 m (7 ft. 9 in.)	2.375 m (7 ft. 9 in.)	2.375 m (7 ft. 9 in.)	2.375 m (7 ft. 9 in.)	2.375 m (7 ft. 9 in.)
<b>C</b> Ground Clearance	0.40 m (15.7 in.)	0.40 m (15.7 in.)	0.40 m (15.7 in.)	0.40 m (15.7 in.)	0.40 m (15.7 in.)	0.40 m (15.7 in.)
<b>D</b> Length From Centerline to Front Axle	1.45 m (4 ft. 9 in.)	1.45 m (4 ft. 9 in.)	1.45 m (4 ft. 9 in.)	1.45 m (4 ft. 9 in.)	1.45 m (4 ft. 9 in.)	1.45 m (4 ft. 9 in.)
<b>E</b> Wheelbase	2.93 m (9 ft. 7 in.)	2.93 m (9 ft. 7 in.)	2.93 m (9 ft. 7 in.)	2.93 m (9 ft. 7 in.)	2.93 m (9 ft. 7 in.)	2.93 m (9 ft. 7 in.)
<b>F</b> Overall Length, Forks on Ground	8.29 m (27 ft. 2 in.)	8.59 m (28 ft. 2 in.)	8.68 m (28 ft. 6 in.)	8.98 m (29 ft. 6 in.)	9.04 m (29 ft. 8 in.)	9.35 m (30 ft. 8 in.)
<b>G</b> Height to Hinge Pin, Fully Raised	3.89 m (12 ft. 9 in.)	3.89 m (12 ft. 9 in.)	4.17 m (13 ft. 8 in.)	4.17 m (13 ft. 8 in.)	4.49 m (14 ft. 9 in.)	4.49 m (14 ft. 9 in.)
<b>H</b> Reach, Fully Raised	0.80 m (31 in.)	0.80 m (31 in.)	0.92 m (3 ft. 0 in.)	0.92 m (3 ft. 0 in.)	0.97 m (3 ft. 2 in.)	0.97 m (3 ft. 2 in.)
<b>I</b> Fork Height, Fully Raised	3.56 m (11 ft. 8 in.)	3.56 m (11 ft. 8 in.)	3.84 m (12 ft. 7 in.)	3.84 m (12 ft. 7 in.)	4.16 m (13 ft. 8 in.)	4.16 m (13 ft. 8 in.)
<b>J</b> Maximum Reach, Fork Level	1.59 m (5 ft. 3 in.)	1.59 m (5 ft. 3 in.)	1.89 m (6 ft. 2 in.)	1.89 m (6 ft. 2 in.)	2.16 m (7 ft. 1 in.)	2.16 m (7 ft. 1 in.)
<b>K</b> Fork Height, Maximum Reach	1.66 m (5 ft. 5 in.)	1.66 m (5 ft. 5 in.)	1.66 m (5 ft. 5 in.)	1.66 m (5 ft. 5 in.)	1.66 m (5 ft. 5 in.)	1.66 m (5 ft. 5 in.)
<b>L</b> Reach, Ground Level	1.03 m (3 ft. 5 in.)	1.03 m (3 ft. 5 in.)	1.40 m (4 ft. 7 in.)	1.40 m (4 ft. 7 in.)	1.72 m (5 ft. 8 in.)	1.72 m (5 ft. 8 in.)
<b>M</b> Depth Below Ground	91 mm (4 in.)	91 mm (4 in.)	190 mm (7 in.)	190 mm (7 in.)	195 mm (8 in.)	195 mm (8 in.)
<b>N</b> Tine Length	1.52 m (60 in.)	1.83 m (72 in.)	1.52 m (60 in.)	1.83 m (72 in.)	1.52 m (60 in.)	1.83 m (72 in.)
<b>O</b> Load Position, 50% Tine Length	0.76 m (30 in.)	0.91 m (3 ft. 0 in.)	0.76 m (30 in.)	0.91 m (3 ft. 0 in.)	0.76 m (30 in.)	0.91 m (3 ft. 0 in.)
<b>Specifications With Forks</b>						
Tipping Load, Straight, No Tire Deflection	7263 kg (16,013 lb.)	6852 kg (15,107 lb.)	6480 kg (14,287 lb.)	6132 kg (13,520 lb.)	5909 kg (13,027 lb.)	5604 kg (12,355 lb.)
Tipping Load, Straight, With Tire Deflection	7068 kg (15,582 lb.)	6669 kg (14,703 lb.)	6309 kg (13,909 lb.)	5973 kg (13,168 lb.)	5751 kg (12,679 lb.)	5451 kg (12,017 lb.)
Tipping Load, 40-deg. Full Turn, No Tire Deflection	6261 kg (13,804 lb.)	5897 kg (13,001 lb.)	5556 kg (12,249 lb.)	5248 kg (11,569 lb.)	5033 kg (11,096 lb.)	4763 kg (10,501 lb.)
Tipping Load, 40-deg. Full Turn, With Tire Deflection	5991 kg (13,208 lb.)	5649 kg (12,454 lb.)	5319 kg (11,726 lb.)	5031 kg (11,091 lb.)	4830 kg (10,648 lb.)	4566 kg (10,066 lb.)
Rated Operating Load, 50% Full-Turn Tipping Load, With Tire Deflection (conforms to ISO 14397-1 and SAE J1197)*	2996 kg (6,604 lb.)	2825 kg (6,227 lb.)	2660 kg (5,863 lb.)	2516 kg (5,546 lb.)	2415 kg (5,324 lb.)	2283 kg (5,033 lb.)
Rated Operating Load, Rough Terrain, 60% Full-Turn Tipping Load, With Tire Deflection (conforms to EN474-3)*	3595 kg (7,925 lb.)	3389 kg (7,472 lb.)	3191 kg (7,036 lb.)	3019 kg (6,655 lb.)	2898 kg (6,389 lb.)	2740 kg (6,040 lb.)
Rated Operating Load, Firm and Level Ground, 80% Full-Turn Tipping Load, With Tire Deflection (conforms to EN474-3)*	4793 kg (10,566 lb.)	4519 kg (9,963 lb.)	4255 kg (9,381 lb.)	4025 kg (8,873 lb.)	3864 kg (8,519 lb.)	3653 kg (8,053 lb.)
Operating Weight	14 108 kg (31,103 lb.)	14 168 kg (31,236 lb.)	14 297 kg (31,520 lb.)	14 357 kg (31,652 lb.)	14 483 kg (31,930 lb.)	14 544 kg (32,063 lb.)

Loader operating information is based on machine with identified linkage and standard equipment, PowerTech PVS 6068 (EPA Final Tier 4/EU Stage V) engine, ROPS cab, rear cast bumper/counterweight, transmission side-frame guards, bottom guards, standard tires, full fuel tank, and 79-kg (175 lb.) operator. This information is affected by changes in tires, ballast, and different attachments. / \*Rated operating capacity based on Deere attachments only.

## Adjustments to Operating Weights and Tipping Loads With Buckets

Adjustments to operating weights, tipping loads, and tires are based on Z-Bar machine with pin-on 2.3-m<sup>3</sup> (3.0 cu. yd.) enhanced-performance bucket with bolt-on cutting edge, ROPS cab, rear cast bumper/counterweight, transmission side-frame guards, bottom guards, standard tires, full fuel tank, and 79-kg (175 lb.) operator\*

	Tipping Load,		Tread Width	Width Over Tires	Vertical Height
	Operating Weight	Straight			
Add (+) or deduct (-) kg (lb.) as indicated for loaders with 3-piece rims					
Michelin 20.5 R 25, 1 Star L-3 XHA2	0 kg (0 lb.)	0 kg (0 lb.)	0 mm (0 in.)	0 mm (0 in.)	0 mm (0 in.)
Bridgestone 20.5 R 25, 1 Star L-3 VJT	+4 kg (+9 lb.)	+3 kg (+6 lb.)	+2 kg (+5 lb.)	+2 mm (+0.1 in.)	-41 mm (-1.6 in.)
Titan 20.5 R 25, 1 Star L-3 STL3	+11 kg (+23 lb.)	+7 kg (+16 lb.)	+7 kg (+14 lb.)	0 mm (0 in.)	-7 mm (-0.3 in.)
Michelin 20.5 R 25, 1 Star L-2 XTLA	-152 kg (-335 lb.)	-107 kg (-235 lb.)	-94 kg (-207 lb.)	0 mm (0 in.)	+4 mm (+0.2 in.)
Bridgestone 20.5 R 25, 1 Star L-2 VUT	-65 kg (-144 lb.)	-46 kg (-101 lb.)	-40 kg (-89 lb.)	0 mm (0 in.)	+3 mm (+0.1 in.)
Titan 20.5 R 25, 1 Star L-2 TGD2	-85 kg (-188 lb.)	-60 kg (-132 lb.)	-53 kg (-116 lb.)	0 mm (0 in.)	-7 mm (-0.3 in.)
Titan 20.5-25, 16 PR L-2	-245 kg (-541 lb.)	-172 kg (-379 lb.)	-152 kg (-335 lb.)	0 mm (0 in.)	+8 mm (+0.3 in.)
Firestone 20.5-25, 16 PR L-2 SGG LD	-280 kg (-617 lb.)	-196 kg (-433 lb.)	-173 kg (-382 lb.)	0 mm (0 in.)	+5 mm (+0.2 in.)
Titan 20.5-25, 12 PR L-2	-266 kg (-587 lb.)	-187 kg (-412 lb.)	-165 kg (-363 lb.)	0 mm (0 in.)	+8 mm (+0.3 in.)
Firestone 20.5-25, 16 PR L-3 SRG LD	-276 kg (-608 lb.)	-194 kg (-427 lb.)	-171 kg (-376 lb.)	0 mm (0 in.)	+8 mm (+0.3 in.)
Michelin 20.5 R 25, 1 Star L2 SNO-PLUS	-96 kg (-212 lb.)	-67 kg (-148 lb.)	-59 kg (-131 lb.)	0 mm (0 in.)	+6 mm (+0.2 in.)
Michelin 620/75R26 MegaXbib <sup>ES</sup>	-189 kg (-417 lb.)	-133 kg (-293 lb.)	-117 kg (-258 lb.)	+187 mm (+7.4 in.)	+247 mm (+9.7 in.)
Michelin 750/65R26 MegaXbib <sup>ES</sup>	+55 kg (+121 lb.)	+38 kg (+85 lb.)	+34 kg (+75 lb.)	+322 mm (+12.7 in.)	+521 mm (+20.5 in.)
CaCl <sub>2</sub> in 20.5-25, L-3 Rear Tires, 75% Fill	+825 kg (+1,820 lb.)	+1157 kg (+2,551 lb.)	+1020 kg (+2,250 lb.)	N/A	N/A

\*May change based on vehicle configuration, weight, or tire-pressure adjustments.

<sup>E</sup>Equipped with 1-piece rims.

<sup>S</sup>Requires 8-deg. rear axle stops.

# 544 P-TIER

While general information, pictures, and descriptions are provided, some illustrations and text may include product options and accessories NOT AVAILABLE in all regions, and in some countries products and accessories may require modifications or additions to ensure compliance with the local regulations of those countries.

## Bucket Selection Guides 544 P-TIER Z-BAR / HIGH-LIFT / HIGH-LIFT PLUS

LOOSE MATERIALS	kg/m <sup>3</sup>	lb./cu. yd.	LOOSE MATERIALS	kg/m <sup>3</sup>	lb./cu. yd.
Chips, pulpwood	288	485	Limestone, coarse, sized	1570	2,546
Cinders (coal, ashes, clinkers)	673	1,124	Limestone, mixed sizes	1682	2,835
Clay and gravel, dry	1602	2,700	Limestone, pulverized or crushed	1362	2,295
Clay, compact, solid	1746	2,943	Sand, damp	2083	3,510
Clay, dry in lump loose	1009	1,701	Sand, dry	1762	2,970
Clay, excavated in water	1282	2,160	Sand, voids, full of water	2083	3,510
Coal, anthracite, broken, loose	865	1,458	Sandstone, quarried	1314	2,214
Coal, bituminous, moderately wet	801	1,350	Shale, broken crushed	1362	2,295
Earth, common loam, dry	1218	2,052	Slag, furnace granulated	1955	3,294
Earth, mud, packed	1843	3,105	Stone or gravel, 37.5 to 87.5-mm (1.5 to 3.5 in.) size	1442	2,430
Granite, broken	1538	2,592	Stone or gravel, 18.75-mm (0.75 in.) size	1602	2,700
Gypsum	2275	3,834			

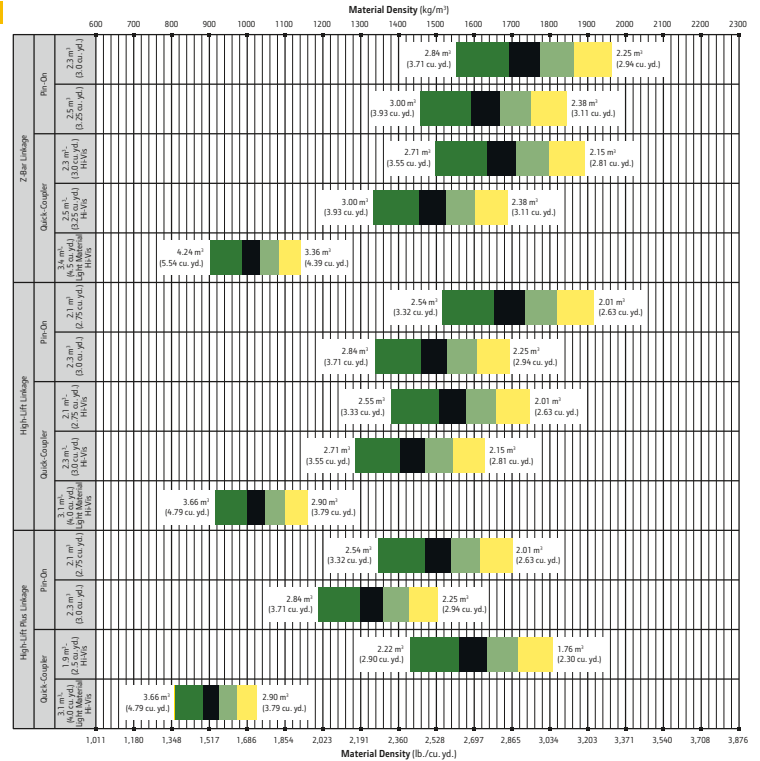
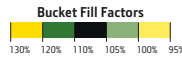

# Additional equipment

Key: ● Standard ▲ Optional or special  
See your John Deere dealer for further information.

## 544 P Engine

- Wet-sleeve cylinder liners
- Programmable auto-idle and auto shutdown
- Selected idle adjustment from 900–1,250 rpm
- Starter excessive-cranking protection
- Automatic engine cool-down timer
- Automatic derating for exceeded system temperatures
- Serpentine drive belt for automatic tensioner
- Electrical fuel-priming pump
- Dual-stage fuel filter and water separator
- 500-hour vertical spin-on oil filter
- ▲ Engine-compartment light
- ▲ Chrome exhaust stack
- Automatic glow plugs for cold start
- ▲ Engine-block heater (recommended for cold starts below –23 deg. C [–10 deg. F])
- ▲ Centrifugal engine air pre-cleaner
- ▲ Throttle lock

## Powertrain

- Clutch cutoff with 4 operator settings: Automatic, level ground, small slope, or steep slope
- Programmable maximum high gear
- Clutch calibration engaged from monitor
- 2,000-hour vertical spin-on transmission filter
- Transmission fill tube and sight gauge
- Transmission diagnostic ports

## 544 P Powertrain (continued)

- ▲ 5-speed transmission with non-lockup torque converter
- 5-speed transmission with lockup torque converter
- Front locking differential
- ▲ Rear locking differential
- Brake retractors and adjusters
- ▲ Automatic differential lock
- Axle oil temperature sensing
- ▲ Wheel-spin control
- ▲ **Quad-Cool™ Cooling System**
- Heavy-duty, trash-resistant radiator and high-ambient cooling package
- 2-side access to all coolers
- Isolated from engine compartment
- Engine radiator
- Engine oil cooler
- Hydraulic oil cooler (oil to air)
- Transmission oil cooler (oil to air)
- Charge air cooler (air to air)
- Fuel cooler
- Coolant recovery tank
- Antifreeze, –37 deg. C (–34 deg. F)
- Cool-on-demand, hydraulically driven, swing-out fan
- Enclosed fan safety guard
- ▲ Automatic reversing fan drive
- ▲ Axle and service-brake coolers

## 544 P Hydraulics

- Electrohydraulic (EH) controls with soft stops and adjustable settings
- In-cab adjustable automatic return-to-dig bucket positioner
- In-cab adjustable automatic boom-height kickout/return to carry
- Reservoir with sight gauge and fill strainer
- Hydraulic diagnostic ports
- 4,000-hour in-tank filter
- 2 function – joystick with F-N-R
- ▲ 2 function – 2-lever fingertip controls and steering column F-N-R
- ▲ 3 function – joystick with F-N-R and integrated 3rd-function roller
- ▲ 3 function – 3-lever fingertip controls and steering column F-N-R
- ▲ 4 function – joystick with F-N-R and integrated 3rd/4th-function rollers
- Programmable multifunction buttons (2)
- Adjustable and continuous hydraulic-flow settings
- Programmable attachment settings
- ▲ Ride control, automatic with monitor-adjustable speed settings
- ▲ Hydraulic control system for quick-coupler locking pins
- ▲ Hydra™ XR cold-temperature hydraulic fluid recommended below –25 deg. C (–13 deg. F)

# Additional equipment *(cont.)*

Key: ● Standard ▲ Optional or special  
See your John Deere dealer for further information.

## 544 P Steering Systems

- Conventional steering wheel with spinner knob
- ▲ Secondary steering

### Electrical

- Solid-state electrical power-distribution system
- Lockable master electrical-disconnect switch
- Battery-terminal safety covers
- By-pass start safety cover at starter
- Remote jump-start access in battery box
- Pre-wired for beacon/strobe light
- Lights: Halogen driving lights with guards (2) / Front (4), rear cab (2), and rear grille (2) work lights / LED front turn signals and flashers / LED stop- and taillights
- ▲ Premium LED light package (all exterior lights are heavy-duty LED)
  - Programmable courtesy lights
  - Horn, electric
  - Reverse warning alarm
- Multifunction/multi-language 178-mm (7 in.) LCD color monitor includes: Digital instruments – Analog display (hydraulic oil temperature, engine coolant temperature, transmission oil temperature, and engine oil pressure) / Digital display (engine rpm, transmission gear/direction indicator, hour meter, fuel level, diesel exhaust fluid (DEF) level, speedometer, odometer, and average fuel consumption)
- ▲ Multifunction/multi-language 127-mm (5 in.) LCD color monitor includes: Digital instruments – Analog display (hydraulic oil temperature, engine coolant temperature, transmission oil temperature, and engine oil pressure) / Digital display (engine rpm, transmission gear/direction indicator, hour meter, fuel level, DEF level, speedometer, odometer, and average fuel consumption)
- ▲ Integrated cycle counter with 5 categories
  - Indicator lights: Standard and selected options / Amber caution and red stop
  - Operator-warning messages
  - Built-in diagnostics: Diagnostic-code details / Sensor values / Calibrations / Individual circuit tester
- ▲ Electrical corrosion-prevention package
  - Standard AM/FM/Weather-Band (WB) radio with remote auxiliary port
- ▲ Premium AM/FM/WB radio with Bluetooth®, remote auxiliary port, and remote USB port (premium cab only)
  - 24- to 12-volt, 8-amp converter and cab power ports (3)
- ▲ 24- to 12-volt, 15- or 30-amp converter and cab power ports (3)

## 544 P Operator's Station

- Standard cab with air conditioning/heater (ROPS/FOPS Level 1, isolation mounted)
- ▲ Premium cab with air conditioning/heater (ROPS/FOPS Level 1, isolation mounted)
- ▲ Automatic temperature control (premium cab only)
  - Rear window defrost vent
  - Keyless start with multiple security modes
  - Sealed-switch module with function indicators
  - Seat with backrest extension, deep foam, fabric cover, and adjustable air suspension
- ▲ Premium seat with high-wide back- and headrest extension, heated and ventilated, leather/fabric cover, and adjustable heavy-duty air suspension
  - Hydraulic controls integrated to seat
  - High-visibility, bright-orange seat belt, 76 mm (3 in.), with retractor
  - ▲ 4-point seat-belt harness
  - ▲ Seat-belt minder monitoring with JDLink™ and seat-belt indicator beacon
  - Cup holder and cup/Thermos® holder with retaining strap
  - Lunch-box/cooler holder with tie-down brackets
  - Coat hook
  - LED dome and reading light
  - Rubber floor mat
  - Dual-tilt steering column
  - Operator's manual storage compartment
  - Outside (2) and inside (1) rearview mirrors
  - ▲ Heated outside mirrors with convex lens
  - ▲ In-cab adjustable heated outside mirrors with convex lens (premium cab only)
  - Left-side operator-station access
  - Fall-arrest system anchor points tested to 2268 kg (5,000 lb.) on front of cab
  - Slip-resistant steps and ergonomic handholds
  - Pull-down front sun visor
  - Front and rear intermittent windshield wipers and washers
- ▲ Powered cab air pre-cleaner
- ▲ Beacon bracket only
- ▲ Beacon bracket with strobe beacon
  - Rearview camera
  - ▲ Rearview camera with radar object-detection system
  - ▲ Dedicated 178-mm (7 in.) rear camera display
  - ▲ Advanced Rear Object-Detection System
  - ▲ Advanced Vision System
  - Payload scale ready
  - ▲ SmartWeigh™ ready + trial
  - ▲ SmartWeigh
  - ▲ SmartDetect™
  - ▲ Fire extinguisher

## 544 P Loader Linkage

- Z-Bar loader linkage (parallel lift)
  - ▲ High-Lift Z-Bar loader linkage (parallel lift)
  - ▲ High-Lift Plus Z-Bar loader linkage (parallel lift)
- ### Buckets and Attachments
- ▲ Full line of Deere pin-on buckets, coupler buckets, and forks
  - ▲ John Deere hydraulic coupler that accepts JRB-pattern attachments
  - ▲ Hi-Vis hydraulic coupler that accepts Euro-pattern attachments (ISO)
- ### Overall Vehicle
- JDLink wireless communication system (available in specific countries; see your dealer for details)
    - NeverGrease™ rear-axle oscillation
    - Front and rear tie-downs
    - Rear cast bumper/counterweight with rear hitch and locking pin
    - Articulation locking bar
    - Loader boom service locking bar
    - 40-deg. steering articulation to each side with rubber-cushion stops on frame
    - Vandal protection with lockable engine enclosures, right counterweight storage, and filler access for radiator/fuel/DEF/hydraulic transmission
    - Left-side service steps and handholds
    - ▲ Left-side service steps and handrails
    - ▲ Left-side close-mounted steps
    - Storage compartment
    - Fuel-tank fill strainer
    - Heavy-duty fuel-tank guard
    - Ground-level fuel and DEF fill
    - Same-side ground-level daily servicing
    - 20.5R25 tires on 3-piece rims
    - ▲ Ag material-handling package
    - ▲ Environmental drains and sample ports for engine, transmission, hydraulic oils, and engine coolant
    - Fenders, front narrow
    - ▲ Fenders, front full width
    - ▲ Fenders, front and rear full width
    - ▲ Fenders, front and rear full width with mud flaps
    - ▲ Less wheels and tires with axle stops
    - ▲ Rims less tires
    - ▲ Transmission side-frame and bottom guards
    - ▲ Lift eyes
    - ▲ License-plate bracket and light

While general information, pictures, and descriptions are provided, some illustrations and text may include product options and accessories NOT AVAILABLE in all regions, and in some countries products and accessories may require modifications or additions to ensure compliance with the local regulations of those countries.

Net engine power is with standard equipment including air cleaner, exhaust system, alternator, and cooling fan at test conditions per ISO 9249. No derating is required up to 3050-m (10,000 ft.) altitude. Specifications and design subject to change without notice. Specifications with the exception of bucket capacity are in accordance with all applicable ISO standards. Except where otherwise noted, these specifications are based on a unit with applicable linkage and standard equipment, ROPS cab, rear cast bumper/counterweight, transmission side-frame guards, bottom guards, standard tires, full fuel tank, and 79-kg (175 lb.) operator.



  
MWS44PAU (24-07)



**JOHN DEERE**