

30 / P

Compact Excavator



JOHN DEERE





DIG THIS BIG “SMALL” IDEA

Working within close lot lines and tight deadlines, you need to get the most from your “mini” machine. Driven to deliver a compact excavator that provides big productivity and outsized versatility, we enhanced our capable 30 P-Tier to boast more lift capacity and breakout force than previous models. And we reimagined the proven standard and optional advantages you’ve come to expect from the John Deere P-Tier lineup. Armed to handle a wide range of underground, building, landscape, and site-development tasks, the 30 P-Tier is also ideal for most rental fleets. Try it on for size.

30 P-TIER COMPACT EXCAVATOR

FEATURES



Make yourself at home

Spacious operator station has a wide entryway and backhoe- to excavator-style controls. Swing boom and foldable travel pedals are positioned for efficient operation and comfortable foot room. Optional four-season cab features front glass that delivers expansive visibility.

Work, run, repeat

Reduced-tail-swing design maximizes maneuverability and performance in cramped places and tight spaces. Compact stature permits easy transport between jobsites, perfect for "dig-and-go" projects.

Go with the flow

More net horsepower than the previous model drives a larger hydraulic pump, increasing productive flow. Higher-flow hydraulic pumps power larger attachments more efficiently.

Get back to it

Standard backfill blade enables the 30 P-Tier to grade and fill, boosting machine versatility and stability when using attachments or working on uneven terrain.

Resource management

Auto-idle automatically reduces engine speed when hydraulics aren't in use. Auto shutdown conserves precious fuel. Power/economy modes optimize power for digging applications, further improving fuel efficiency.



**MANEUVERABLE 31"
TAIL-SWING RADIUS**
WITH STANDARD ARM

Quick-change artist

Standard selector valve allows the connection of two attachments at the same time by changing the valve position to divert supply/return oil from one to the other. Wedge-style coupler enables quick changes and accepts a wide variety of buckets and attachments, such as hydraulic hammers, plate compactors, and augers.

It hardly seems like work

Track speeds automatically slow to low whenever a heavier load is encountered, then return to high when the load normalizes. No pedal or operator activation is required for high-speed travel.

See what you can do

Conveniently located in a compartment beneath the seat, control pattern selector valve includes a sight glass that displays the selected pattern.

As tough as they come

Heavy-duty side shields deflect material and impacts, protecting propel motors and boom/blade cylinders. Securely clamped steel hydraulic lines and CORDURA® covering on rubber hoses provide extra durability. Box-constructed X-frame and track frames are rock solid and rugged.

Maintenance matters

Hinged door provides wide-open access to the side-by-side oil cooler and radiator. Cooler system is designed to resist trash buildup and allow quick and easy core cleanout. Extended service intervals let the machine work longer before maintenance is needed.



30 P-TIER COMPACT EXCAVATOR



**ACCEPTS ATTACHMENTS
COMMON TO OTHER
DEERE COMPACTS**

Make the most of your investment

Already own some John Deere attachments? Many models including buckets, hydraulic hammers, and augers also work on other compact machines so you can redefine fleet utilization — and your bottom line.

Connected machines

John Deere construction equipment comes with in-base connectivity — free from subscriptions or annual renewals. Analyze critical machine data, track utilization, review diagnostic alerts, and more from **the John Deere Operations Center™**. The Operations Center also enables **John Deere Connected Support™**, which uses data from thousands of connected machines to proactively address issues before they arise. Your dealer can also remotely monitor machine health, diagnose problems, and even update machine software without a trip to the jobsite.*

*Availability varies by region and product. Options not available in every country.



While general information, pictures, and descriptions are provided, some illustrations and text may include product options and accessories NOT AVAILABLE in all regions, and in some countries products and accessories may require modifications or additions to ensure compliance with the local regulations of those countries.

Engine		30 P-TIER	
Manufacturer and Model	Yanmar 3TNV88F-EPHB	Displacement	1.642 L (100.2 cu. in.)
Non-Road Emission Standard	EPA Final Tier 4/EU Stage IV	Net Rated Power (ISO 9249)	17.4 kW (23 hp) at 2,400 rpm
Powertrain			
2-speed propel with automatic shift			
Maximum Travel Speed		Swing Speed, Right and Left	9.1 rpm
Low	2.8 km/h (1.7 mph)	Swing Brake	Spring applied, hydraulically released, automatic, disc type
High	4.3 km/h (2.7 mph)		
Hydraulics			
Open center, pilot operated, with 2 variable-displacement pumps and single-gear pilot pump			
Maximum Rated Flow		Controls	Pilot levers; short-stroke, low-effort hydraulic pilot controls with shutoff lever
Main Pumps	2 x 38.4 L/m (2 x 10.1 gpm)		
Pilot Pump	22.8 L/m (6.0 gpm)		
Auxiliary Hydraulics	61.2 L/m (16.2 gpm)		
Electrical			
Alternator Rating	55 amp		
Work Lights		2 halogen, 1 mounted on operator station, and 1 mounted on boom	
Undercarriage			
Planetary final drives with axial-piston motors; propel motor shields			
Track-Shoe Width, Standard Configuration	300 mm (11.8 in.)		
Ground Pressure With 300-mm (12 in.) Triple Semi-Grouser Shoes			
Canopy	28 kPa (4.1 psi)		
Cab	30 kPa (4.4 psi)		
Upperstructure			
Maximum Boom-Swing Angle	<i>Canopy</i>	<i>Cab</i>	
Left	72 deg.	62 deg.	
Right	62 deg.	62 deg.	
Serviceability			
Refill Capacities		Refill Capacities (continued)	
Fuel Tank	42.0 L (11.1 gal.)	Travel Gearcase (each; qty. 2)	0.60 L (0.6 qt.)
Engine Coolant	5.0 L (1.3 gal.)	Hydraulic System	56.0 L (14.8 gal.)
Engine Oil With Filter	7.2 L (1.9 gal.)	Hydraulic Tank	43.0 L (11.4 gal.)
Operating Weights			
With 328-kg (723 lb.) Counterweight, Standard Front Attachments, Full Fuel Tank, and 75-kg (165 lb.) Operator			
300-mm (12 in.) Rubber Track (canopy with operator)	3105 kg (6,850 lb.)		
300-mm (12 in.) Rubber Track (cab with operator)	3275 kg (7,220 lb.)		
Operating Dimensions			
1.17-m (3 ft. 10 in.) Standard Arm and Standard Counterweight			
	<i>Canopy</i>	<i>Cab</i>	
A Maximum Cutting Height	4.62 m (15 ft. 2 in.)	4.42 m (14 ft. 6 in.)	
B Maximum Dumping Height	3.20 m (10 ft. 6 in.)	3.03 m (9 ft. 11 in.)	
C Maximum Digging Depth	2.79 m (9 ft. 2 in.)	2.79 m (9 ft. 2 in.)	
D Maximum Digging Reach	4.89 m (16 ft. 1 in.)	4.89 m (16 ft. 1 in.)	
E Minimum Boom-Swing Radius	1.58 m (5 ft. 2 in.)	1.82 m (6 ft. 0 in.)	
F Transport Length	4.45 m (14 ft. 7 in.)	4.45 m (14 ft. 7 in.)	
Machine Dimensions			
Blade			
Width	1740 mm (5 ft. 9 in.)		
Height	373 mm (15 in.)		

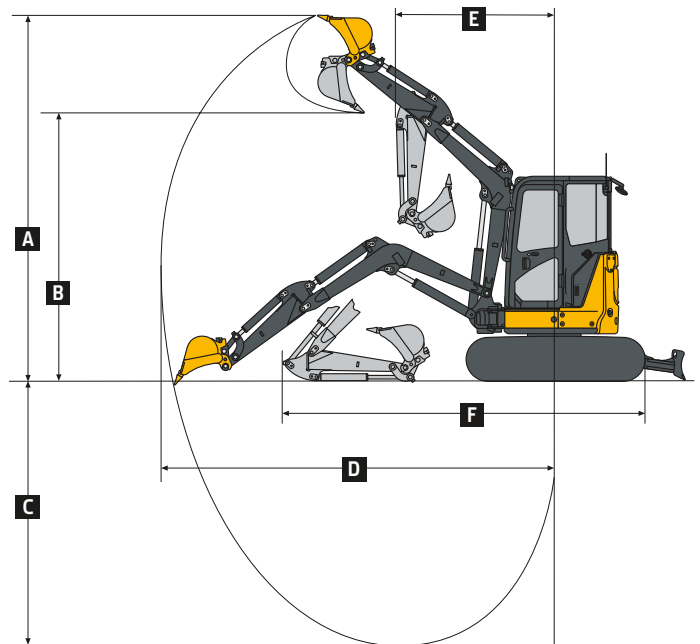

30 P-TIER COMPACT EXCAVATOR SPECIFICATIONS

30

P

While general information, pictures, and descriptions are provided, some illustrations and text may include product options and accessories NOT AVAILABLE in all regions, and in some countries products and accessories may require modifications or additions to ensure compliance with the local regulations of those countries.

Machine Dimensions (continued)	30 P-TIER
G Upperstructure Width	1.55 m (5 ft. 1 in.)
H Overall Height, Canopy or Cab	2.48 m (8 ft. 2 in.)
I Track Width	300 mm (12 in.)
J Undercarriage Width	1.55 m (5 ft. 1 in.)
K Ground Clearance	280 mm (11 in.)
L Tail-Swing Radius (with standard arm)	775 mm (31 in.)
M Engine Cover Height	1.53 m (5 ft. 0 in.)
N Maximum Blade Lift Above Ground	360 mm (14 in.)
O Maximum Blade Drop Below Ground	360 mm (14 in.)
P Sprocket Center to Idler Center	1.66 m (5 ft. 5 in.)
Q Undercarriage Length	2.11 m (6 ft. 11 in.)
R Counterweight Clearance	0.55 m (22 in.)

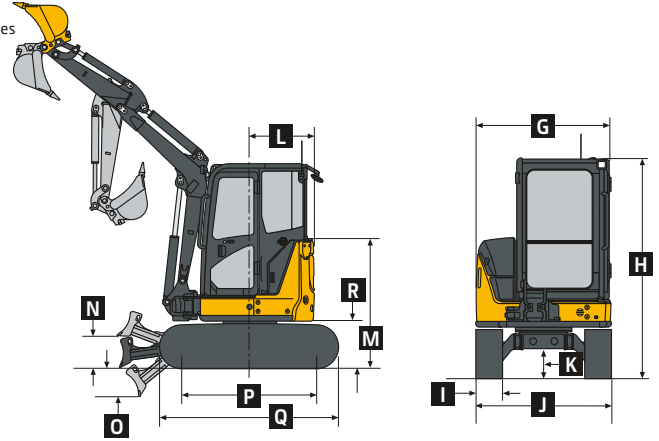

Lift Capacities

Boldface type indicates hydraulically limited capacities; lightface type indicates stability-limited capacities, in kg (lb.). All lift capacities are based on ISO 10567 (with power boost). Machine situated on firm, level, uniform supporting surface. Total load includes weight of cables, hook, etc. Figures do not exceed 87% of hydraulic capacity or 75% of weight needed to tip machine.

1.17-m (3 ft. 10 in.) Arm, 81.5-kg (180 lb.)

Bucket, 328-kg (723 lb.) Counterweight, and 300-mm (12 in.) Track Shoe	Canopy, Blade on Ground, Over Front*	Canopy, Blade on Ground, Over Side	Cab, Blade on Ground, Over Front*	Cab, Blade on Ground, Over Side
Ground Level at 3.0-m (10 ft.) Radius	1440 kg (3,170 lb.)	480 kg (1,050 lb.)	1440 kg (3,170 lb.)	510 kg (1,124 lb.)

*Blade down (limited by hydraulics).

Additional equipment

Key: ● Standard ▲ Optional or special
See your John Deere dealer for further information.

30 P Engine

- Meets EPA Final Tier 4/EU Stage IV emissions
- Engine coolant to -37 deg. C (-34 deg. F)
- Engine preheater
- Fan guard
- Fuel/water separator
- Full-flow oil filter
- Isolation mounted
- Key start switch with electric fuel shutoff
- Single dry-type air filter
- Auto-idle
- Auto shutdown

Hydraulic System

- Auxiliary function right-hand pilot-lever control
- Auxiliary hydraulic lines to end of boom
- ▲ Auxiliary hydraulic lines with quick-couplers to end of boom
- Auxiliary selector valve
- Axial-piston swing motor
- Boom-swing foot control
- Excavator-to-backhoe control pattern change valve
- Open center with 2 variable-displacement pumps, 1 fixed-gear pump, and 1 pilot pump
- Hydraulic pilot-operated controls for boom, arm, bucket, swing, boom swing, blade, travel, and auxiliary functions
- Wet-disc swing brake

30 P Undercarriage

- Planetary final drive
- Propel motor shield
- 2-speed axial-piston propel motors
- Rubber track, 300 mm (12 in.)

Upperstructure

- 360-deg. rotation
- Counterweight, 328 kg (723 lb.)
- Hinged service-access doors
- ROPS/TOPS/FOPS (canopy)
- ▲ ROPS/TOPS/FOPS (cab) with air conditioning and heater

- Vandal protection for service doors, fuel cap, and toolbox
- Reduced-tail-swing configuration

Front Attachments

- Arm, 1.17 m (3 ft. 10 in.)
- Backfill blade, 1.74 m (5 ft. 9 in.)
- Boom, 2.465 m (8 ft. 1 in.)
- Mechanical quick-coupler
- ▲ Augers: Planetary / Chain drive / Bits / Bit adapters
- ▲ Clamp
- ▲ Hammers: Points / Tools
- ▲ Quick-coupler buckets: Bucket teeth / Ditching / Heavy-duty

Operator's Station

- Horn
- Hour meter
- Instrumentation lights

30 P Operator's Station (continued)

- Mode selectors (illuminated): Power mode (I) / Eco mode (I)
- Monitor system: Preheat indicator / Engine oil pressure indicator with alarm / Alternator voltage indicator / Fuel gauge and low-fuel-level indicator / Engine coolant temperature gauge and engine coolant temperature indicator with alarm / Hour meter / Work lights indicator
- Motion alarm with cancel switch
- Work lights switch
- Propel levers and foldable pedals
- 2 travel speeds with automatic shifting
- Seat belt, 51 mm (2 in.), retractable
- ▲ Seat belt, 76 mm (3 in.), retractable
- Suspension seat, vinyl, with fore/aft adjustment
- ▲ Suspension seat, cloth (cab only)
- ▲ Front screen

Electrical

- 12-volt accessory outlet
- Alternator, 55 amp
- Low-maintenance battery
- Blade-type multi-fused circuits
- Positive-terminal battery covers
- ▲ JDLink™ connectivity hardware and John Deere Operations Center™ account

Lights

- Work lights: Halogen / 1 mounted on operator's station / 1 mounted on boom

Net engine power is with standard equipment including air cleaner, exhaust system, alternator, and cooling fan at test conditions per ISO 9249. These machines are not equipped with spark-arrestor mufflers. Usage in forestry applications is not recommended. Specifications and design subject to change without notice. Wherever applicable, specifications are in accordance with SAE standards. Except where otherwise noted, these specifications are based on a canopy unit with standard arm, 300-mm (12 in.) rubber track, 328-kg (723 lb.) counterweight, full fuel tank, and 79-kg (175 lb.) operator.



ME30PAU (23-07)

 **JOHN DEERE**