

750L

Dozer



JOHN DEERE



PACKED TO POWER YOUR PRODUCTIVITY

When you work in site development, roadbuilding, or material handling, you need to get the most from your equipment and your operators. We've relied on input from real-world customers like you to design and manufacture our dozers for nearly 75 years. The John Deere 750L features some of your best ideas, like generous horsepower, reliable systems, durable components, and flexible grade-control solutions that can be easily and economically upgraded. And because retaining skilled and productive operators is always a priority, we've made the operating experience an important part of what the 750L Dozer has to offer.

High comfort and low effort

A 14-percent-larger cab than the previous model features more glass area, larger doors, and a streamlined hood profile, optimizing comfort and visibility to the blade ahead and the surrounding jobsite. Ergonomic joysticks enable intuitive, low-effort command of the transmission, hydraulics, and rear implement, and also include proportional blade-angle control. Large, easy-to-navigate monitor provides push-button access to a wealth of machine information, including temperatures, pressures, and diagnostics.

It all adds up

Delivering six-percent more horsepower than the 750K, the 750L has the highest horsepower and largest blade capacity in its size class. Even with the added power, fuel consumption remains comparable to the previous series. Combined with additional weight over its predecessor, the 750L is 12-percent more productive in backfilling applications than its closest competitor.

Hydrostatic dynamics

The John Deere hydrostatic system simplifies operation and redefines durability. Each track has its own independent hydrostatic pump and motor, and the blade and ripper functions have their own independent hydraulic pump, allowing both transmission and hydraulic operating characteristics to be tailored to individual preference without sacrificing hydraulic speed. And heavy loads can be carried through turns and counter-rotations while the dozer is in gear or neutral.

At your service

Routing of the electrical and hydraulic systems has been significantly simplified to nearly eliminate wear points, improving reliability and ease of maintenance over earlier models. Enlarged service doors provide quick access to conveniently located checkpoints and filters. Hydraulic and hydrostatic oil-change intervals extended from 2,000 to 4,000 hours help further minimize maintenance and expense.





GRADE-MANAGEMENT SOLUTIONS

Our suite of factory-integrated grade-management technologies including optional 2D Slope Control and SmartGrade™ 3D grade control simplify difficult grading tasks. These intuitive offerings are easy for operators of any experience level to master. All technology options are fully supported by the John Deere dealer network and can be efficiently upgraded as your operation evolves:

- **Slope Control** assists in grading and maintaining flat, smooth, and sloping surfaces. Operators can view and set blade slope while the system automatically controls the blade to the desired slope percentage.
- Fully integrated **SmartGrade** features next-generation components and integration, enabling the highest levels of productivity and grading performance.
- Standard **electrohydraulic (EH) controls** make it easy to add the grade-control system of your choice.



GRADE-MANAGEMENT OPTIONS
**STREAMLINE
GRADING TASKS &
LEARNING CURVES**

Turn, turn, turn

Independent track control speeds up or slows down each side, for smooth, full-power turns. Automatic power boost helps carry big blade loads through turns.

Blade basics

Optional 161-inch-wide blade for the 750L enables coverage of larger jobsites in fewer passes. With heavy-duty crossmembers and high-profile push beams, the outside dozer (OSD) blade option is designed for high-production performance.

Opt for easier workdays

Optional automatic temperature control (ATC) system allows operators to select a desired temperature instead of fiddling with knobs to get comfortable. Both the standard deluxe fabric-covered seat and optional premium leather-accented heated/ventilated seat help enhance the in-cab experience. Add an optional rearview camera to see behind the dozer on the color monitor.

Ready for rugged

The 750L has been beefed-up with thicker sheet metal, a heavier-duty mainframe, and a more robust c-frame-to-mainframe joint than previous models. A durable heavy-duty undercarriage comes standard. Or opt for Extended Life undercarriage with SC-2™-treated bushings, a proven parts coating that delivers up to twice the wear life.

Every drop counts

Standard Eco mode adjusts engine power and transmission settings automatically based on load while maintaining ground speed, improving fuel economy up to 15 percent over the previous series with no loss of productivity. Auto-idle also helps save fuel by reducing engine speed when the dozer isn't moving. Auto shut-down turns the engine off after an operator-determined period of idling, further minimizing fuel use while reducing wear on components.



**MAKE FEWER PASSES
ON LARGER JOBSITES
WITH OPTIONAL 161"-WIDE BLADE**



750L DOZER



Clear the way

Factory-installed limb risers and screens allow you to put this versatile dozer to work in forestry, land-clearing, and other challenging applications.

Precision Construction

From grade management and obstacle detection to product automation features and jobsite intelligence, this suite of construction technology delivers productivity solutions to help you get more done, more efficiently.

John Deere construction equipment comes with in-base connectivity — free from subscriptions or annual renewals. Analyze critical machine data, track utilization, review diagnostic alerts, and more from **the John Deere Operations Center™**. The Operations Center also enables **John Deere Connected Support™**, which uses data from thousands of connected machines to proactively address issues before they arise. Your dealer can also remotely monitor machine health, diagnose problems, and even update machine software without a trip to the jobsite.*

*Availability varies by region and product. Options not available in every country.



750L DOZER SPECIFICATIONS

Engine	750L XLT / 750L LGP	750L
Blade Type	Power-Angle-Tilt (PAT)	Outside Dozer (OSD)
Manufacturer and Model	John Deere PowerTech™ PVS 6068	John Deere PowerTech PVS 6068
Non-Road Emission Standard	EPA Final Tier 4/EU Stage V	EPA Final Tier 4/EU Stage V
Displacement	6.8L (414 cu. in.)	6.8L (414 cu. in.)
SAE Net Rated Power	131 kW (175 hp) at 1,700 rpm	131 kW (175 hp) at 1,700 rpm
Aspiration	Turbocharged with charge-air cooler	Turbocharged with charge-air cooler
Air Cleaner	Vacuum-aspirated dual-element dry canister	Vacuum-aspirated dual-element dry canister
Cooling	750L XLT / 750L LGP / 750L	
Type	Variable-speed suction fan with automatic reversing	
Engine Coolant Rating	-37 deg. C. (-34 deg. F)	
Engine Radiator	10 fins per in.	
Powertrain	Automatic, dual-path, hydrostatic (HST) drive; load-sensing feature automatically adjusts speed and power to match changing load conditions; each individually controlled track is powered by a variable-displacement piston pump and motor combination; ground-speed selection buttons on single-lever steering and direction control; reverse speed ratio is fully operator customizable; decelerator pedal provides infinite speed control from full speed to complete stop	
Transmission	Automatic, dual-path, hydrostatic (HST) drive; load-sensing feature automatically adjusts speed and power to match changing load conditions; each individually controlled track is powered by a variable-displacement piston pump and motor combination; ground-speed selection buttons on single-lever steering and direction control; reverse speed ratio is fully operator customizable; decelerator pedal provides infinite speed control from full speed to complete stop	
System Relief Pressure	47 574 kPa (6,900 psi)	
Travel Speeds		
Forward and Reverse	9.7 km/h (6.0 mph)	
Maximum (optional)	11.0 km/h (6.8 mph)	
Steering	Single-lever steering, speed, direction control, and counter-rotation; full power turns and infinitely variable track speeds provide unlimited maneuverability and optimum control; HST steering eliminates steering clutches and brakes	
Final Drives	Double-reduction, planetary final drives mounted independently of track frames and dozer push frames for isolation from shock loads	
Total Ratio	46.41 to 1	
Drawbar Pull		
Maximum	259 kN (58,250 lb.)	
At 1.9 km/h (1.2 mph)	167 kN (37,500 lb.)	
At 3.2 km/h (2.0 mph)	106 kN (23,750 lb.)	
Brakes		
Service	HST (dynamic) braking stops the machine whenever the direction-control lever is moved to neutral or the decelerator is depressed to the detent	
Parking	Exclusive safety feature engages wet, multiple-disc brakes whenever the engine stops, the decelerator is depressed to the end of travel, or motion is detected while the transmission control is in neutral; machine cannot be driven with brake applied, minimizing wearout; spring applied, hydraulic release	
Hydraulics	750L XLT / 750L LGP	750L
Type	Open-center load-sense hydraulic system with variable-displacement piston pump	
Pump Displacement	63 cc	
System Relief Pressure	24 993 kPa (3,625 psi)	
Differential Pressure	1896 kPa (275 psi)	
Maximum Flow at Unloaded High Idle	130 L/m (34 gpm)	
Control	3-function electrohydraulic (EH) joystick with proportional roller-angle function	2-function EH joystick
Electrical	750L XLT / 750L LGP / 750L	
Voltage	24 volts	
Capacity		
Battery	950 CCA	
Reserve	175 min.	

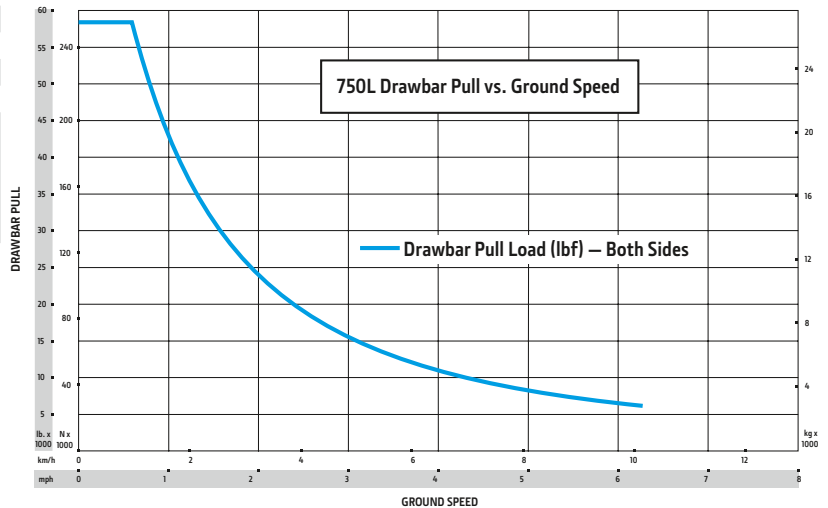

While general information, pictures, and descriptions are provided, some illustrations and text may include product options and accessories NOT AVAILABLE in all regions, and in some countries products and accessories may require modifications or additions to ensure compliance with the local regulations of those countries.

Electrical (continued)		750L XLT / 750L LGP / 750L			
Alternator Rating					
Cab	145 amp				
Canopy	110 amp				
Lights					
Halogen	Cab-mounted front (2), cab-mounted rear (2), and engine compartment (1)				
Premium LED	Cab-mounted front (4), cab-mounted rear (2), and engine compartment (1)				
Undercarriage		750L XLT	750L LGP	750L	
Blade Type	PAT	PAT	OSD		
Tracks	Track frame with front and rear track guides and sprocket guard; John Deere undercarriage features deep heat-treated, sealed, and lubricated track links and through-hardened, sealed, and lubricated rollers for maximum wear resistance; sprockets are segmented; extreme-duty shoes are available (on some models) for severe applications				
Track Gauge	1880 mm (74 in.)	2134 mm (84 in.)	2134 mm (84 in.)	1880 mm (74 in.)	
Grouser Width	559 mm (22 in.)	860 mm (34 in.)	860 mm (34 in.)	610 mm (24 in.)	
Chain	Sealed and lubricated		Sealed and lubricated		Sealed and lubricated
Shoes, Each Side	45	45	45	40	
Track Rollers, Each Side	8	8	8	7	
Track Length on Ground	3093 mm (122 in.)	3093 mm (122 in.)	3093 mm (122 in.)	2604 mm (103 in.)	
Ground Contact Area	38 232 cm ² (5,926 sq. in.)	58 373 cm ² (9,048 sq. in.)			35 677 cm ² (5,530 sq in.)
Ground Pressure	43.7 kPa (6.34 psi)	30.5 kPa (4.42 psi)	30.5 kPa (4.43 psi)	47.8 kPa (6.93 psi)	
Track Pitch	191 mm (7.5 in.)	191 mm (7.5 in.)	191 mm (7.5 in.)	191 mm (7.5 in.)	
Oscillation at Front Roller	±135 mm (±5.3 in.)	±127 mm (±5.0 in.)	±127 mm (±5.0 in.)	±110 mm (±4.3 in.)	
Operator Station		750L XLT / 750L LGP / 750L			
ROPS (ISO 3471 – 2008) and FOPS (ISO 3449 – 2005) Level II					
Serviceability					
Refill Capacities					
Fuel Tank With Lockable Cap	370 L (97.7 gal.)				
Cooling System With Recovery Tank	31.4 L (8.3 gal.)				
Engine Oil With Filter	28 L (7.4 gal.)				
Reservoir With Filter					
Transmission	57 L (15.1 gal.)				
Hydraulic	98 L (25.9 gal.)				
Diesel Exhaust Fluid (DEF) Reservoir	14.2 L (3.8 gal.)				
Operating Weights		750L XLT	750L LGP	750L	
<i>Base Weight (with standard equipment, rollover protective structure [ROPS], full fuel tank, and 79-kg [175 lb.] operator)</i>	17 041 kg (37,569 lb.)	18 133 kg (39,976 lb.)	18 162 kg (40,040 lb.)	17 386 kg (38,330 lb.)	
Optional Components					
Cab With Pressurizer and Heater/ Air Conditioner	230 kg (507 lb.)	230 kg (507 lb.)	230 kg (507 lb.)	230 kg (507 lb.)	
Rear Screen					
ROPS Canopy	28 kg (62 lb.)	28 kg (62 lb.)	28 kg (62 lb.)	28 kg (62 lb.)	
Cab With Air Conditioner	49 kg (108 lb.)	49 kg (108 lb.)	49 kg (108 lb.)	49 kg (108 lb.)	
Screens – Full Enclosure, Cab With Air Conditioner	219 kg (483 lb.)	219 kg (483 lb.)	219 kg (483 lb.)	219 kg (483 lb.)	
Limb Risers (ROPS canopy and cab)	186 kg (410 lb.)	186 kg (410 lb.)	186 kg (410 lb.)	186 kg (410 lb.)	
Heavy-Duty Grille	30 kg (65 lb.)	30 kg (65 lb.)	30 kg (65 lb.)	30 kg (65 lb.)	
Rear Counterweight	326 kg (720 lb.)	326 kg (720 lb.)	326 kg (720 lb.)	326 kg (720 lb.)	
Retrieval Hitch	37 kg (81 lb.)	37 kg (81 lb.)	37 kg (81 lb.)	37 kg (81 lb.)	
Drawbar, Extended Rigid	111 kg (245 lb.)	111 kg (245 lb.)	111 kg (245 lb.)	111 kg (245 lb.)	
Center Chain Guides	61 kg (135 lb.)	61 kg (135 lb.)	61 kg (135 lb.)	61 kg (135 lb.)	
Full-Length Rock Guards	221 kg (487 lb.)	221 kg (487 lb.)	221 kg (487 lb.)	178 kg (392 lb.)	
Track Shoes					
559-mm (22 in.) Moderate Duty	In base	–759 kg (–1,674 lb.)	–759 kg (–1,674 lb.)	–	
610-mm (24 in.) Moderate Duty	86 kg (190 lb.)	–673 kg (–1,484 lb.)	–673 kg (–1,484 lb.)	In base	
610-mm (24 in.) Extreme Duty	350 kg (772 lb.)	–409 kg (–902 lb.)	–409 kg (–902 lb.)	230 kg (507 lb.)	
710-mm (28 in.) Moderate Duty	–	–363 kg (–800 lb.)	–363 kg (–800 lb.)	–	
860-mm (34 in.) Moderate Duty	–	In base	In base	–	

While general information, pictures, and descriptions are provided, some illustrations and text may include product options and accessories NOT AVAILABLE in all regions, and in some countries products and accessories may require modifications or additions to ensure compliance with the local regulations of those countries.

750L DOZER SPECIFICATIONS (continued)

Machine Dimensions	750L XLT	750L LGP	750L
Blade Type	Power-Angle-Tilt (PAT)	Power-Angle-Tilt (PAT)	Outside Dozer (OSD)
A Overall Height to Roof (includes antenna base and grouser height)	3248 mm (10 ft. 8 in.)	3248 mm (10 ft. 8 in.)	3248 mm (10 ft. 8 in.)
A' Overall Height With Limb Risers (includes grousers)	3343 mm (11 ft. 6 in.)	3343 mm (11 ft. 6 in.)	3343 mm (11 ft. 6 in.)
B Tread Depth With Single-Bar Grouser			
Moderate Duty	69 mm (2.7 in.)	69 mm (2.7 in.)	69 mm (2.7 in.)
Extreme Duty	69 mm (2.7 in.)	69 mm (2.7 in.)	69 mm (2.7 in.)
C Ground Clearance in Dirt	358 mm (14 in.)	358 mm (14 in.)	358 mm (14 in.)
D Overall Length	5359 mm (211 in.) (17 ft. 7 in.)	5359 mm (211 in.) (17 ft. 7 in.)	6054 mm (238 in.) (19 ft. 10 in.)
D' Overall Length With Extended Drawbar	5602 mm (221 in.) (18 ft. 5 in.)	5602 mm (221 in.) (18 ft. 5 in.)	6297 mm (248 in.) (20 ft. 8 in.)
E Blade Lift Height	904 mm (36 in.) (3 ft. 0 in.)	904 mm (36 in.) (3 ft. 0 in.)	1035 mm (40.7 in.) (3 ft. 4.7 in.)
F Blade Digging Depth	648 mm (25.5 in.)	648 mm (25.5 in.)	594 mm (23.4 in.)
G Blade Cutting-Edge Angle, Adjustable	54.3 to 59.4 deg.	54.3 to 59.4 deg.	51.2 to 59.2 deg.

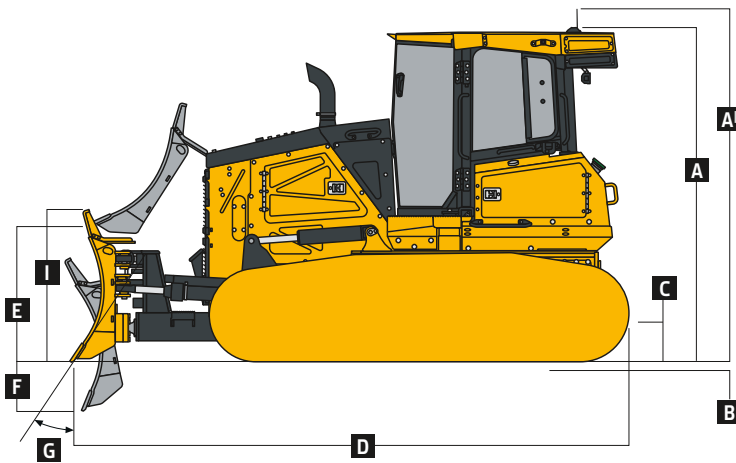

750L XLT / 750L LGP WITH POWER-ANGLE-TILT (PAT) BLADE

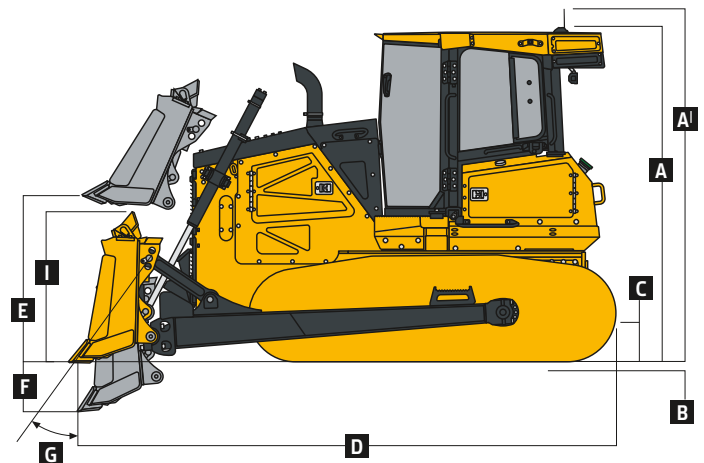

750L WITH OUTSIDE DOZER (OSD) BLADE

Machine Dimensions (continued)	750L XLT	750L LGP	750L
Semi-U			
H Blade Width	—	—	3265 mm (129 in.) (10 ft. 9 in.)
I Blade Height	—	—	1435 mm (56.5 in.) (4 ft. 8.5 in.)
SAE Capacity	—	—	4.3 m ³ (5.6 cu. yd.)
Weight	—	—	1350 kg (2,976 lb.)
Push-Beam Assembly Weight (without blade)	—	—	1274 kg (2,809 lb.)
L Blade Tilt	—	—	681 mm (27 in.)
N Width Over Track	—	—	2440 mm (96 in.) (8 ft. 0 in.)

While general information, pictures, and descriptions are provided, some illustrations and text may include product options and accessories NOT AVAILABLE in all regions, and in some countries products and accessories may require modifications or additions to ensure compliance with the local regulations of those countries.

Machine Dimensions (continued)	750L XLT	750L LGP	750L
Blade Type	PAT	PAT	OSD
Straight			
H Blade Width	3296 mm (130 in.) (10 ft. 10 in.)	3962 mm (156 in.) (13 ft. 0 in.)	4083 mm (161 in.) (13 ft. 5 in.)
I Blade Height	1444 mm (57 in.) (4 ft. 9 in.)	1427 mm (56 in.) (4 ft. 8 in.)	—
SAE Capacity	3.9 m ³ (5.2 cu. yd.)	4.5 m ³ (5.9 cu. yd.)	4.6 m ³ (6.0 cu. yd.)
Weight	967 kg (2,132 lb.)	1111 kg (2,449 lb.)	1140 kg (2,513 lb.)
C-Frame Assembly Weight (without blade)	1324 kg (2,926 lb.)	1324 kg (2,926 lb.)	1324 kg (2,926 lb.)
J Blade Angle	24 deg.	24 deg.	24 deg.
K Overall Width With Blade Angled	3011 mm (118.5 in.) (9 ft. 10.5 in.)	3619 mm (142.5 in.) (11 ft. 10.5 in.)	3729 mm (147 in.) (12 ft. 3 in.)
L Blade Tilt	432 mm (17 in.)	502 mm (20 in.)	518 mm (20 in.)
M Cut Reach	57 mm (2 in.)	116 mm (5 in.)	171 mm (7 in.)
N Width Over Track	2440 mm (96 in.) (8 ft. 0 in.)	2989 mm (118 in.) (9 ft. 10 in.)	—
O Cast Reach	457 mm (18 in.)	515 mm (20 in.)	571 mm (22.5 in.)

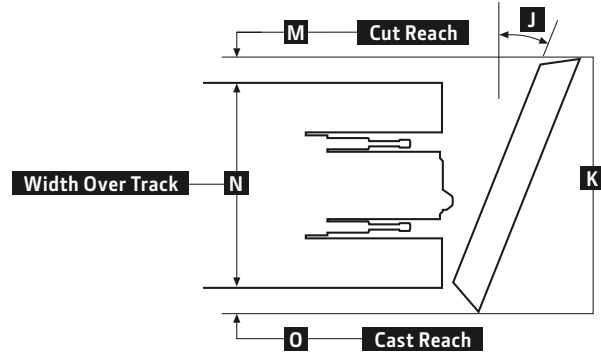
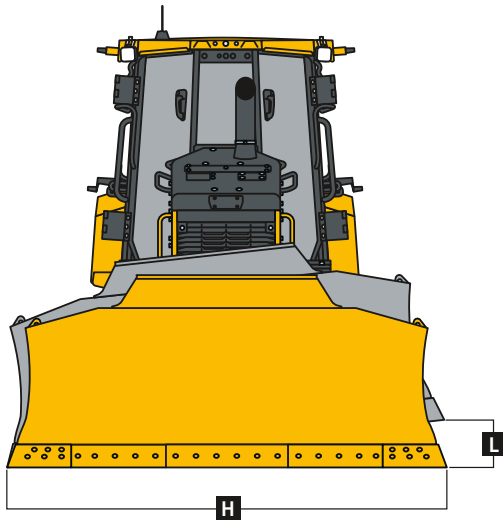

Rear Ripper 750L XLT / 750L LGP / 750L

Multi-shank (3) parallelogram ripper	
Weight	1957 kg (4,314 lb.)
P Maximum Penetration	741 mm (29 in.)
Q Maximum Clearance Under Tip	638 mm (25 in.)
R Overall Length, Lowered Position	1689 mm (67 in.) (5 ft. 7 in.)
R' Overall Length, Raised Position	1448 mm (57 in.) (4 ft. 9 in.)
S Overall Beam Width	2134 mm (84 in.) (7 ft. 0 in.)
T Slope Angle (full raise)	22 deg.
U Ripping Width	1880 mm (74 in.) (6 ft. 2 in.)
V Distance Between Shanks	902 mm (36 in.) (3 ft. 0 in.)

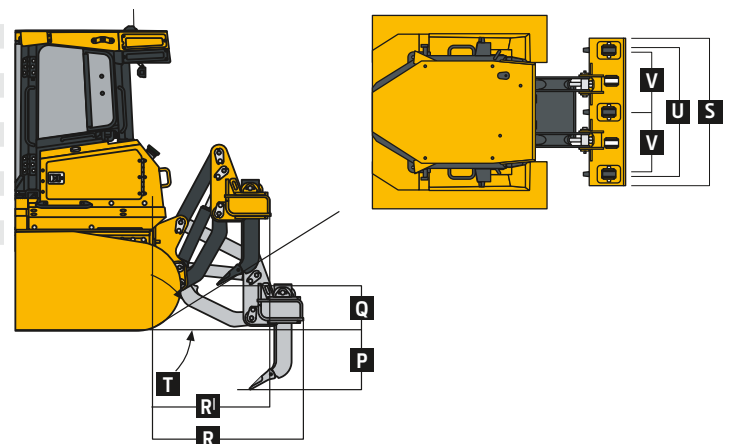

While general information, pictures, and descriptions are provided, some illustrations and text may include product options and accessories NOT AVAILABLE in all regions, and in some countries products and accessories may require modifications or additions to ensure compliance with the local regulations of those countries.

Additional equipment

Key: ● Standard ▲ Optional or special

See your John Deere dealer for further information.

750L Engine

- Meets EPA Final Tier 4/EU Stage V emissions
- John Deere PowerTech™ PVS 6068 6.8L engine
- Wet-sleeve cylinder liners
- Eco mode
- Exhaust stack, black
- ▲ Exhaust stack, chrome
- Turbocharged and air-to-air after-cooled
- Dual-element dry-canister air cleaner
- Engine glow-plug starting system
- Programmable auto engine shutdown
- Automatic turbo cool-down timer
- Exhaust filter, under hood, with vertical stack
- Fuel filters with automatic electronic priming
- ▲ Severe-duty fuel filter
- ▲ Engine coolant heater, 120 volt
- 110-amp alternator (canopy)
- 145-amp alternator (cab)

Cooling

- Hydraulically driven cooling fan, variable-speed suction type
- Engine cooling rated -37 deg. C (-34 deg. F)
- Automatic, programmable reversing fan
- Engine radiator, hydrostatic (HST) cooler, and hydraulic cooler, 10 fins per inch

750L Cooling (continued)

- Enclosed safety fan guard (conforms to SAE J1308 and ISO 3457)
- Single-plane non-stacked cooler design

Powertrain

- Dual-path HST transmission
- Reverse-speed ratios (100%, 115%, and 130% presets or operator defined)
- Operator-selectable decelerator function (hydrostats and engine or hydrostats only)
- Single-lever steering with counter-rotate function
- Full power turns with infinitely variable track speed
- HST (dynamic) service brakes
- Wet, multi-disc parking brake
- Remote diagnostic test ports
- Automatic cold-weather transmission warmup system
- Automatic transmission derating for exceeded system temperatures
- Vented dedicated transmission reservoir and filtration system separate from hydraulic system

Hydraulic System

- Load-sense electrohydraulic (EH) system with variable-displacement piston pump
- 3-spool EH control valve for Power-Angle-Tilt (PAT)

750L Hydraulic System (continued)

- 3-spool EH control valve for Outside Dozer (OSD) with single auxiliary
- ▲ 4-spool EH control valve for PAT with single auxiliary
- Grade-control-ready EH hydraulics
- ▲ SmartGrade™ ready including Slope Control system
- ▲ SmartGrade 3D mastless grade control including Slope Control
- Hydrau™ All-Season Hydraulic Oil, -25 deg. C to 50 deg. C (-13 deg. F to 122 deg. F)
- ▲ Hydrau™ XR Hydraulic Oil, -40 deg. C to 40 deg. C (-40 deg. F to 104 deg. F)
- ▲ Cylinder-rod scrapers (PAT only)
- Hydraulic pump, standard
- ▲ Hydraulic pump, high flow
- ▲ Hydraulic pump for direct-drive winch
- Vented dedicated hydraulic reservoir and filtration system separate from transmission system

Undercarriage

- Full-length, smooth-surface track frame covers
- Double-flange rollers
- Oscillating undercarriage
- Heavy-duty sealed and lubricated undercarriage
- ▲ Extended Life undercarriage with SC-2™ bushings
- ▲ Full-length rock guards

While general information, pictures, and descriptions are provided, some illustrations and text may include product options and accessories NOT AVAILABLE in all regions, and in some countries products and accessories may require modifications or additions to ensure compliance with the local regulations of those countries.

Net engine power is with standard equipment including air cleaner, exhaust system, alternator, and cooling fan at test conditions specified per ISO9249. No derating is required up to 3050-m (10,000 ft.) altitude. Also available: winches, fair-leads, log arches, skidding grapples, trash packages, landfill protection packages, cable plows, side booms, field-installed cab for canopy, canopy heater, and fire-suppression systems. Specifications and design subject to change without notice. Wherever applicable, specifications are in accordance with SAE standards. Except where otherwise noted, these specifications are based on a unit with ROPS, full fuel tank, and 79-kg (175 lb.) operator. Operator station ROPS and FOPS certified.

Additional equipment *(continued)*

Key: ● Standard ▲ Optional or special

See your John Deere dealer for further information.

750L Operator's Station	
▲	Canopy cab with under-seat heater
▲	Enclosed cab with air/heat
▲	Automatic temperature control (ATC) system
●	Standard seat, vinyl with heavy-duty air suspension (canopy)
●	Deluxe seat, cloth with heavy-duty air-suspension (cab)
▲	Premium seat, leather-accented, heated and ventilated, with heavy-duty air-suspension (cab)
●	Under-seat heater (canopy)
●	AM/FM/Weather-Band (WB) radio with front auxiliary (cab)
▲	Premium radio with Bluetooth®, AM/FM/WB radio, remote auxiliary, and remote USB port (cab)
●	Multifunction/multi-language 178-mm (7 in.) color LCD monitor: Tachometer, hour meter, transmission direction and speed (forward/reverse), exhaust filter status, ambient temperature, and clock
●	Built-in diagnostics: Diagnostic-code details / Sensor values / Calibrations / Individual circuit tester
●	Backup alarm
▲	Rearview camera
●	12-volt accessory plug (1)
▲	Additional 12-volt accessory plug

750L Operator's Station <i>(continued)</i>	
●	Keyless start with multiple security codes
●	Retractable seat belt, 76 mm (3 in.) (conforms to SAE J368)
▲	Fire extinguisher mounting bracket
▲	External-mounted rear-attachment mirror (cab)
●	Front, door, and rear wipers and washers (cab)
Overall Vehicle	
●	Environmental drain package
▲	Fluid-sample ports
●	JDLINK™ wireless machine communication system (available in specific countries; see your local dealer for details)
▲	Quick service ports (HST, hydraulic, and engine oil, and coolant)
●	Halogen lights: cab-mounted front (2) and cab-mounted rear (2)
▲	Premium LED lights: cab-mounted front (4) and cab-mounted rear (2)
●	Engine-compartment light
▲	Beacon light
▲	Trimble-ready interface package
▲	Leica-ready interface package
▲	Heavy-duty grille
▲	Final-drive trash guards (waste applications)

750L Overall Vehicle <i>(continued)</i>			
▲	Full screens for cab		
▲	Rear window screen		
▲	Large debris prescreen		
▲	Forestry limb risers (sweeps)		
●	Lockable master electrical disconnect switch		
Attachments			
▲	Rear ripper, parallelogram		
▲	Single rear counterweight		
▲	Retrieval hitch with pin		
▲	Retrieval hitch with 1 counterweight		
▲	Extended rigid drawbar		
▲	Extended rigid drawbar with 1 counterweight		
▲	Threaded pitch jack (OSD only)		
STD	XLT	LGP	750L Shoes
	●	▲	559-mm (22 in.) moderate service
●	▲	▲	610-mm (24 in.) moderate service with clipped corners
▲	▲	▲	610-mm (24 in.) extreme service with clipped corners
		▲	710-mm (28 in.) moderate service
		●	860-mm (34 in.) moderate service with clipped corners

While general information, pictures, and descriptions are provided, some illustrations and text may include product options and accessories NOT AVAILABLE in all regions, and in some countries products and accessories may require modifications or additions to ensure compliance with the local regulations of those countries.

Net engine power is with standard equipment including air cleaner, exhaust system, alternator, and cooling fan at test conditions specified per ISO9249. No derating is required up to 3050-m (10,000 ft.) altitude. Also available: winches, fair-leads, log arches, skidding grapples, trash packages, landfill protection packages, cable plows, side booms, field-installed cab for canopy, canopy heater, and fire-suppression systems. Specifications and design subject to change without notice. Wherever applicable, specifications are in accordance with SAE standards. Except where otherwise noted, these specifications are based on a unit with ROPS, full fuel tank, and 79-kg (175 lb.) operator. Operator station ROPS and FOPS certified.



DKALDZR750 (23-09)



JOHN DEERE